

# UCD-340

## User Manual

UCD Console SW Version 3.9



## Copyright

This manual, Copyright © 2025 Unigraf. All rights reserved

Reproduction of this manual in whole or in part without written permission of Unigraf is prohibited.

## Notice

The information given in this manual is verified in the correctness on the date of issue. The authors reserve the rights to make any changes to this product and to revise the information about the products contained in this manual without an obligation to notify any persons about such revisions or changes.

## Company Information

Unigraf

Piispantilankuja 4  
FI-02240 ESPOO  
Finland

Tel. +358 9 859 550

<mailto:info@unigraf.fi>

<https://www.unigraf.fi>

<http://www.unigraf-china.cn>

## Edition

UCD-340 UCD Console 3.9 User Manual, Rev 1

Date: 20 March 2026

## Trademarks

Unigraf, UCD, UCD-340, UCD Console and TSI are trademarks of Unigraf Oy.

DisplayPort™ and the DisplayPort™ logo are trademarks owned by the Video Electronics Standards Association (VESA®) in the United States and other countries.

The Adopted Trademarks HDMI, High-Definition Multimedia Interface, the HDMI Logo, and HDMI Port Logo are trademarks or registered trademarks of HDMI Licensing Administrator, Inc. in the United States and other countries.

HDCP is a trademark of Digital Content Protection LLC.

Altera and Intel FPGA are trademarks of Intel Corporation or its subsidiaries in the U.S. and/or other countries.

Windows® 11 and Windows® 10 are trademarks of Microsoft Corporation.

All other trademarks are properties of their respective owners.

## Limited Warranty

Unigraf warrants its hardware products to be free from defects in workmanship and materials, under normal use and service, for twelve (12) months from the date of purchase from Unigraf or its authorized dealer.

If the product proves defective within the warranty period, Unigraf will provide repair or replacement of the product. Unigraf shall have the whole discretion whether to repair or replace, and replacement product may be new or reconditioned. Replacement product shall be of equivalent or better specifications, relative to the defective product, but need not to be identical. Any product or part repaired by Unigraf pursuant to this warranty shall have a warranty period of not less than 90 days, from the date of such repair, irrespective of any earlier expiration of original warranty period. When Unigraf provides replacement, then the defective product becomes the property of Unigraf.

Warranty service may be obtained by contacting Unigraf within the warranty period. Unigraf will provide instructions for returning the defective product.

## CE Mark

UCD-300 family products meet the essential health and safety requirements, is in conformity with and the CE marking has been applied according to the relevant EU Directives using the relevant section of the corresponding standards and other normative documents.

## Table of Contents

	Copyright .....	2
	Notice.....	2
	Company Information.....	2
	Edition .....	2
	Trademarks.....	3
	Limited Warranty.....	3
	CE Mark .....	3
	Table of Contents.....	4
1.	About This Manual .....	7
	Purpose.....	7
	Product and Software Version .....	7
	Notes.....	7
2.	Introduction.....	8
	Product Description .....	8
	UCD-340 .....	9
	USB-C External Power Test Unit.....	12
	Safety and Operational Precautions.....	13
	Compliance Information .....	13
	End-of-life Handling.....	15
3.	Installation .....	16
	Installation Package .....	16
	Software Installation.....	16
	Firmware Update Procedure .....	18
	Firmware Downgrading.....	20
	Device Roles .....	21
	Change Device Configuration .....	22
	License Manager.....	23
	UCD Console .....	25
	Device Selection .....	25
	Analyzer and Generator Operation .....	25
	UCD Console Menu .....	26
	Detaching and Cloning Tabs .....	29
4.	Analyzer Operation .....	30
	Functionality Tabs .....	30
	Functionality Tabs .....	31
	Video Tab.....	31
	Capture Tab.....	39
	Audio Tab.....	40
	EDID Tab.....	42
	HDCP Tab.....	43
	Source DUT Testing Tab.....	44
	Link Tab .....	31
	DPCD Tab.....	46
	SDP Tab.....	47
	AUX Controller Tab.....	49
	USB-C Monitoring .....	51
	USB-C Power Delivery Tab (PDC) .....	51
	Status List .....	52
	Capabilities .....	54
	DP Alt Mode.....	56
	Power Source .....	57
	Power Sink.....	58
	Controls .....	<b>Error! Bookmark not defined.</b>
	Bottom Panel.....	60
5.	Generator Operation.....	61
	Functionality Tabs .....	61

	Functionality Tabs .....	62
	Link Tab .....	62
	Pattern Generator Tab .....	66
	Playback Tab .....	70
	Audio Generator Tab.....	80
	HDCP Tab .....	81
	EDID Tab.....	82
	Sink DUT Testing Tab .....	83
	DPCD Tab .....	85
	USB-C Monitoring .....	86
	USB-C Power Delivery Tab .....	86
6.	UCD Timeline viewer .....	87
7.	Event Log.....	91
	Logged Events .....	92
	Event Transaction List.....	93
	Customizing Transaction List .....	94
	Parsed Transactions .....	96
8.	EDID Editor .....	98
	Controls .....	98
	EDID Editor Features.....	99
	Editing Tips .....	99
9.	Packet Editor.....	101
	Introduction.....	101
10.	Pattern Editor .....	102
	Introduction.....	102
11.	Image Converter .....	104
	Appendix A: Product Specification.....	105
	UCD-340 .....	105
	Appendix B: Product Features .....	106
	UCD-340 .....	106
	UCD-340 (cont.).....	107
	Appendix C: Predefined Timings .....	108
	Appendix D: Predefined Patterns.....	114
	Fixed Patterns .....	114
	Extended Patterns.....	115
	Extended Patterns (contd.).....	116
	Extended Patterns (contd.).....	117
	Extended Patterns (contd.).....	118
	Appendix E: Sink and Source DUT Tests.....	119
	Test Report .....	120
	Audio Test Set – DP Alt Mode Rx.....	121
	CRC Video Tests –DP Alt Mode Rx .....	122
	Electrical Test Set – DP Rx.....	125
	Link Config Tests – DP Rx.....	129
	Pixel Level Video Tests – DP Rx, HDMI Rx .....	130
	Appendix F: Vpattern Language .....	131
	General .....	131
	Commands.....	132
	Variables .....	138
	Appendix H: Playlists and Scenarios.....	140
	Playlists .....	141
	Scenarios .....	142
	Parameters.....	142
	Example .....	145
	Sample Content in Playback Tab .....	147
	DP .....	147
	Playlist: Basic Video & Audio Example .....	148
	Playlist: Audio-Video Latency .....	149

Playlist: HDR & Metadata Example .....	150
Playlist: Grayscale .....	151
Playlist: HDR10+ SSTM Example (DP) .....	152
Playlist: Frame Rate Example (DP) .....	153
Playlist: PSR1 (DP) .....	154
Version History .....	155

# 1. ABOUT THIS MANUAL

## Purpose

This guide is User Manual of UCD-340, USB-connected video interface test units for use with a PC with Windows® 11, Windows® 10 or Windows® 8 operating system.

The purpose of this guide is to

- Provide an overview of the products and their features.
- Provide instructions for the user on how to install the software and the drivers.
- Provide instructions for the user on how to update the FW of the unit.
- Introduce the HW features of the units.
- Provide instructions for the user on how to use UCD Console software.

## Product and Software Version

This manual explains features found in UCD Console Software Bundle **3.9**. Please consult Unigraf for differences or upgrades of previous versions.

Please consult the Release Notes document in the installation package for details of the SW and FW versions and changes to previous releases.

## Notes

On certain sections of the manual, when important information or notification is given, text is formatted as follows. Please read these notes carefully.

---

**Note:** This text is an important note

---

---

**Note:** This version of the User Manual describes features in UCD Console software version 2 based on the functionality in Microsoft Windows operating system.

UCD Console is available also for macOS operating system to be used in iMac and MacBook computers and for Linux operating system.

Detailed description of the macOS and Linux versions will be added later.

---

## 2. INTRODUCTION

### Product Description

UCD-300 family are high speed, USB 3.0 connected video interface test unit. UCD-300 series consists of the following units:

UCD-340	USB-C DisplayPort Alt Mode analyzer and generator
USB-C External Power Test Unit	Accessory to UCD-340 for testing Power load for USB-C Sink or Source DUT.

*UCD Console* is user interface (GUI) for UCD family test equipment for desktop use. The outlook and details of UCD Console will vary depending on the capabilities of the connected unit and will reflect the features enabled.

Unigraf UCD units feature a high-level Software Development Kit (SDK) called Test Software Interface (TSI) for use in automated testing. TSI allows for an easy integration of Production and R&D testing routines into an automated test system environment. Please refer to TSI documentation found in additional Unigraf manuals for more details.

## UCD-340

### UCD-340 Product Features

- Test unit for testing power delivery and DP Alt Mode functions of USB-C interface
- Monitoring and control of data and power delivery roles of the USB-C interface
- Optional Power Test Unit for testing high voltage and power options

Please refer to Product *Specifications* in the appendix of this document for details.

### Functional Description

UCD-340 is an integrated test unit for verifying the performance of PD and DP Alt Mode functions in a USB Type-C device.

UCD-340 unit consist of a USB-C signal input stage with data multiplexer with either two directional data pass-through to USB2 or USB3 interfaces or connection to DP Alt Mode input / output block.

The USB-C input stage consists of capability for electrically testing the continuity of input signals. An optional separate Power Test unit is sourcing or sinking the various voltages for testing USB-C power options.

The DP Alt Mode block includes frame grabber and pattern generator functions for emulating DP Alt Mode source and sink functions.

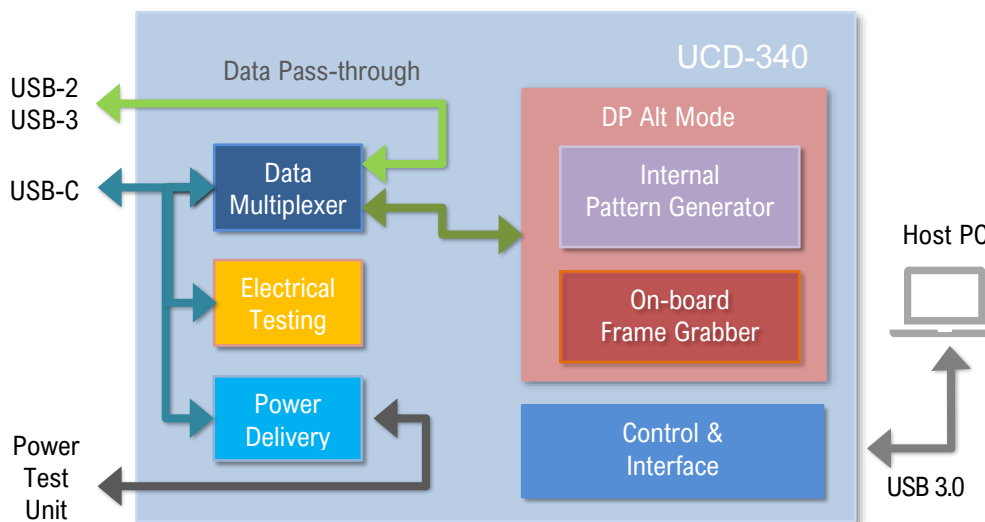

### Delivery Content

UCD-340 product shipment contains:

- The UCD-340 unit
- AC/DC Power supply (100 to 240 Vac 50/60 Hz input, +12 Vdc output)
- USB 3.0 compliant cable
- USB-C to USB-C test cable
- Unigraf Electrical test cable (with units including Electrical Test)

## UCD-340 Connections

The image below indicates the connections in UCD-340 unit and their description

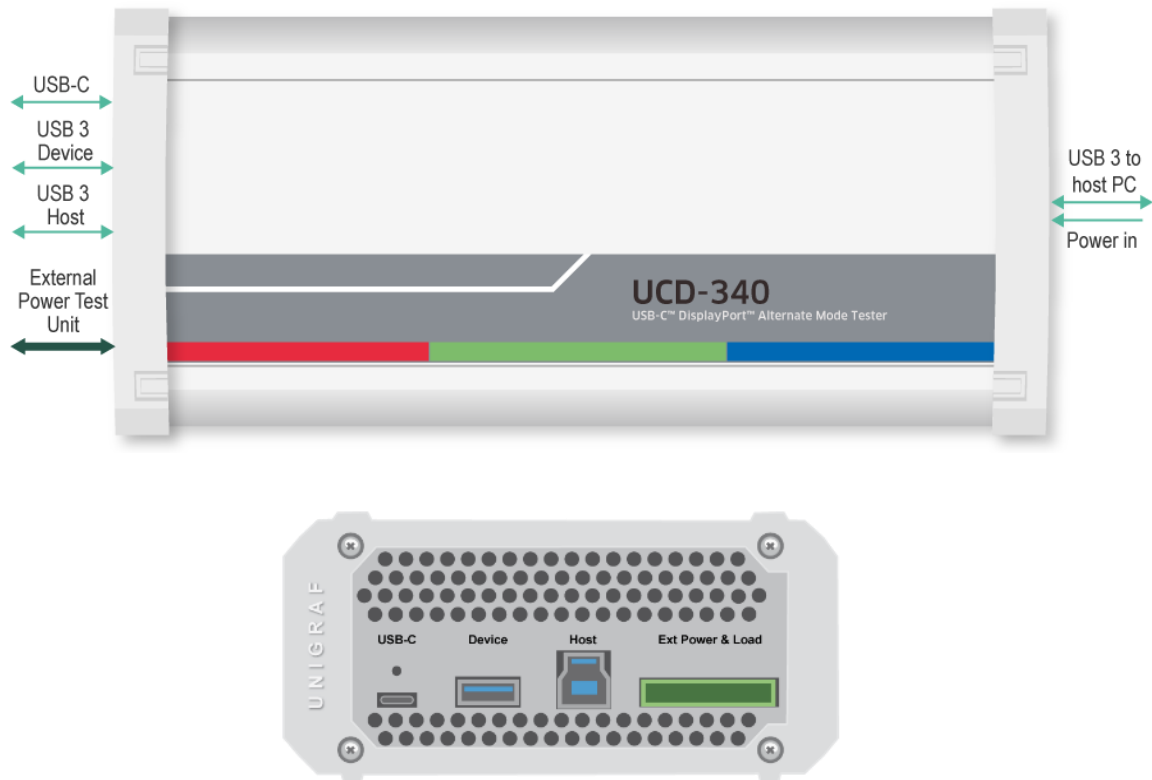

Name	Description
USB-C	USB Type-C Connection to the evaluated device (DUT)
USB 3 Device	USB Type-A connector for an auxiliary USB 3.1 “Device” for data pass-through
USB 3 Host	USB Type-B connector for an auxiliary USB 3.1 “Host” for data pass-through
External Power Test Unit	Connector for Unigraf’s “USB-C External Power Test Unit”
Power in	+12 Vdc Power Supply Input
USB 3 to host PC	USB 3.0 connection to the controlling PC

---

**Note:** Capturing and sourcing high resolution video modes, especially 4K video modes set stringent requirements on the video cables and connectors. Please contact Unigraf for assistance and details about evaluated cables.

---



---

**Warning** In order to avoid possible damage to the UCD unit and the PC, please **always attach the power cord (Power In) to UCD-300 unit first**, and after that connect the USB cable to your PC.

---

## Unigraf Electrical Test Cable to UCD-340

Some features of the Electrical Test function in UCD-340 are available only when using the special Electrical Test Cable provided by Unigraf. Electrical Test Cable includes extra wires enabling UCD-340 to individually measure the electrical continuity of DUT's four VBUS and four GND signals that are normally tied together at DUT's end of the cable. Please refer to the image below for clarification.

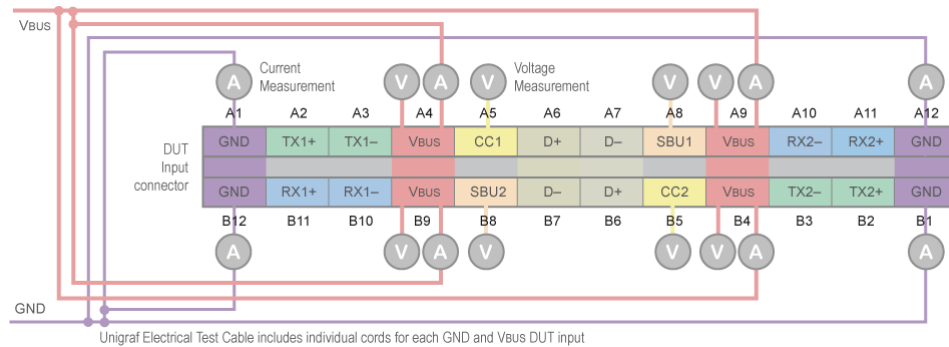

**Note:** When attaching Unigraf Electric Test Cable, please make sure that the finger-screw is tightened all-the-way into its hole. When tightened, the finger-screw triggers a switch indicating the presence of Unigraf Electric Test Cable.

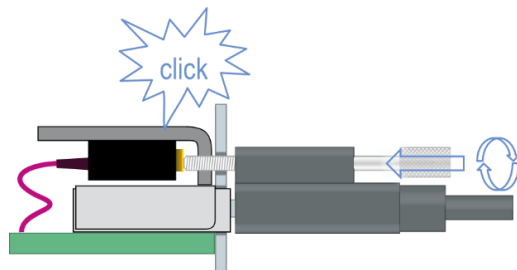

You can also verify that Unigraf Test Cable is plugged from UCD Console by selecting vertical Tab **USB-C**, horizontal tab **Roles and Modes**. The indicator text can be found in the bottom bar.

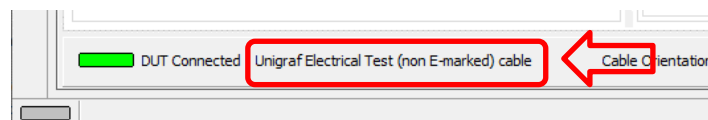

### Two Electrical Test Cable Types

Please note that there are two versions for Unigraf Electrical Test Cable. The difference is the number of USB D+/- pairs included in the cable.

- If DUT has shorted USB2.0 pins A6 to B6 and A7 to B7 at the receptacle then choose cable One: In order to minimize in-cable signal coupling only one USB D+/- pair is included in the cable
- If DUT has shorted USB2.0 pins routed to mux or similar, then choose cable Two: In order to enable electrical cable flip in cases where USB D+ lines and USB D- lines correspondingly have not been shorted together on Device side, both USB D+/- pairs are included in the cable. This cable marked with a label "2xUSB 2.0 PAIRS".

## USB-C External Power Test Unit

Unigraf *External USB-C Power Test Unit* connected to UCD-340 enables testing extended USB power options. Please find below a matrix describing Power Source and Power Sink options of UCD-340 internally and with attached *Unigraf External Power Test Unit*. Please find description of controlling the power options with UCD Console later in this manual.

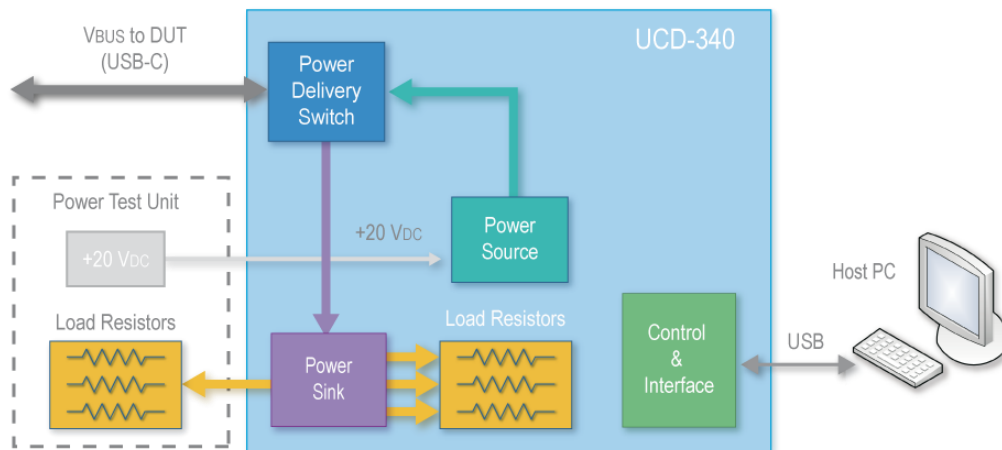

### Power Test Capability

The table below indicates which Vbus voltages and current ranges are available with UCD-340 only and which with UCD-340 combined with USB-C External Power Test Unit

Used equipment:	5 V				9 V	12 V	15 V	20 V
	0.5 A	0.9 A	1.5 A	3 A	3 A	3 A	3 A	5 A
<b>Vbus Source capability</b>								
UCD-340	•	•	•	•				
UCD-340 with USB-C External Power Test Unit	•	•	•	•	•	•	•	•
<b>Vbus Sink capability</b>								
UCD-340	•	•	•	•				
UCD-340 with USB-C External Power Test Unit	•	•	•	•	•	•	•	•

## Safety and Operational Precautions

Please find below the **Safety Precautions** for using the Unigraf UCD test instrument. Please also carefully read the **Notes and Warnings** within the text of this manual.

These **Precautions and Warnings** are provided to enable a safe use of the UCD test equipment. Therefore, Unigraf assumes no liability when the user fails to follow the expressed **Precautions and Warnings**.

- Use only Unigraf provided AC/DC Power Adapter. Please make sure that connectors and cabling to the Power Adapter are intact. In case there are any doubts about the condition of the Adapter or cabling, stop using it immediately.
- It is important to ensure that the used AC input voltage is within the specified range (100 to 240 Vac 50/60 Hz) and the fuses in the AC lines are of the specified type. If in doubt, do not connect the device.
- UCD devices are rated for indoor use only. They are rated for Pollution Degree 2 as defined in IEC 61010-1. This classification corresponds to usage in a typical office or home environment. Under normal use, only dry, non-conductive pollution occurs. Occasionally, temporary conductivity caused by condensation can be expected. Temporary condensation occurs only when the product is out of service.
- To ensure compliance with all applicable EMC standards, use high-quality shielded interface cables. The clamp-on ferrite supplied with the product must be installed on the USB cable.
- When installing the unit, connect the Power Adapter to the UCD device first, after that connect the AC plug. Please disconnect the USB cable to the controlling PC and remove cabling to DUT while connecting the power input cables.
- It is forbidden to open the housing of the UCD device without written permission from Unigraf. Failure to comply with this rule will void the warranty of the unit.
- UCD devices are intended for use as Electrical Test Instrument only. Use for other purposes is forbidden.
- Use UCD equipment only in its specified ambient temperature and humidity.
- In order to ensure that the UCD device and associated SW will operate properly, please ensure that the PC used for controlling the UCD device complies with the minimum requirement set by Unigraf.
- Please keep UCD software updated by regularly checking the updates on Unigraf download page (<https://www.unigraf.fi/downloads/>). Please update the device firmware to match the installed software.

## Compliance Information

This section lists all the applicable Safety, Electromagnetic Compatibility (EMC), and Environmental standards with which the instrument complies as well as the end-of-life handling requirements for proper disposal of the instrument. This product is intended for use by professionals and trained personnel only; it is not designed for use in households or by children. The following certifications and compliance markings are applicable to the product.

### CE Certification



CE marking is a certification mark that indicates conformity with health, safety, and environmental protection standards for products sold within the European Economic Area.

The product meets intent of the European Council Directives 2014/35/EU for Product Safety, 2014/30/EU for Electromagnetic Compatibility (EMC) and 2011/65/EU for Restriction of Hazardous Substances (RoHS). Compliance was demonstrated to the following specifications as listed in the Official Journal of the European Communities:

### Safety Compliance

- EN 61010-1:2010+A1:2019 Safety requirements for electrical equipment for measurement, control and laboratory use.
- EN IEC 61010-2-030:2021 Particular requirements for testing and measuring circuits.

### EMC Compliance<sup>1</sup>

- EN IEC 61326-1:2021 EMC requirements for electrical equipment for measurement, control, and laboratory use.
- EN IEC 61326-2-1:2021 Particular requirements for sensitive test and measurement equipment for EMC unprotected applications.

<sup>1</sup> This product is intended for use in nonresidential areas only. Use in residential areas may cause electromagnetic interference. To ensure compliance with all applicable EMC standards, use high-quality shielded interface cables. The clamp-on ferrite supplied with the product must be installed on the USB cable.

### RoHS Compliance

- EN 63000:2018 Technical documentation for the assessment of electrical and electronic products with respect to the restriction of hazardous substances

Unless otherwise specified, all the materials and processes are compliant with the Restriction of Hazardous Substances (RoHS) Directive 2011/65/EU in its entirety, inclusive of any further amendments or modifications of said Directive.

## End-of-life Handling

### WEEE Certification



WEEE marking indicating separate collection for WEEE- Waste of electrical and electronic equipment. The instrument is marked with this symbol to indicate that it complies with the applicable European Union requirements of Directives 2012/19/EU and 2006/66/EC on Waste Electrical and Electronic Equipment (WEEE) and Batteries.

### CHINA RoHS Certification



China RoHS 10 marking is a certification mark that indicates conformity with the Chinese government regulation to control the restriction of hazardous substances for products shipped to China.

Unless otherwise specified, all the materials and processes are compliant with the latest requirements of China RoHS 2. The hazardous substances contained in the instrument are disclosed in accordance with the standards SJ/T 11364-2014 (Marking for the restricted use of hazardous substances in electronic and electrical products) and GB/T 26572-2011 (Requirements on concentration limits for certain restricted substances in electrical and electronic products). The instrument is marked with an appropriate Environment Friendly Use Period (EFUP) symbol.

## 3. INSTALLATION

### Installation Package

The UCD software installation package can be obtained from Unigraf download page at <https://www.unigraf.fi/downloads/>. Please, note that there are separate packages for Windows and macOS.

The installation package is a bundle between the components needed for UCD Console SW and for TSI SDK. The bundle contains the following items:

- Windows/macOS drivers (installed during set up)
- UCD Console SW (installed during set up)
- License Manager (installed during set up)
- Device configuration utility (installed during set up)
- Packet Editor (installed during set up)
- TSI SDK
- User Manuals including this document.
- In some cases, also the firmware of the unit needs to be updated. If in doubt, please contact Unigraf.

---

**Note:** The software should be installed before connecting the UCD unit to the PC.

---

---

**Note:** System administrator's privileges are required for performing the installation.

---

### Software Installation

#### Windows

- ▶ Install \*.exe file from the package.
- ▶ Start installation by running application **SoftwareBundle\_X.X.XXXX**.

The welcome page is displayed and shows the software package release version.

The user is also asked if he/she wants to:

- Create a desktop shortcut
- Install the Visual C++ redistributable (needs to be present on Windows)
- Install Unigraf USB drivers
- ▶ Confirm by selecting *Next* dialog button. Select *Install* to start the installation.
- ▶ Select *Finish* to exit the installation dialog.

#### macOS

- ▶ Install \*.pkg file from the package. This is a universal binary for ARM and Intel x86.
- ▶ Start installation by running application **SoftwareBundle\_X.X.XXXX**.
- ▶ Confirm by selecting *Next* dialog button. Select *Install* to start the installation.
- ▶ Select *Finish* to exit the installation dialog.

Note: If you are downgrading, please remove the *Unigraf UCD Tools* folder from the *Applications* folder before starting installation.

Note: If installation fails, remove the *Unigraf UCD Tools* folder and any possible copies from the *Applications* directory and try again.

## Linux

- ▶ Linux extract the \*.tar.gz file. You will find two install scripts (*install-libfuse.sh* and *install.sh*).
- ▶ In the Files app select each script in turn, right click and select *Properties* to open the *Properties dialog*. Toggle the *Executable as Program* button.
- ▶ In the Files app open a terminal window by unselecting any selected files and right clicking and selecting *Open in Terminal* to run the scripts (order is important).
- ▶ In the terminal type: `sudo ./install-libfuse.sh`
- ▶ You will be prompted for you password.
- ▶ Type: `sudo ./install.sh`
- ▶ You will be prompted with:  
*Please proceed to 'Software & updates' application to tab 'Other Software' and uncheck checkboxes or remove 'cdrom' entry from /etc/apt/sources.list file. Otherwise you will have problems during UCD Console package installation. If you are already done, enter the key 'y'. If not - 'n'*
- ▶ For Ubuntu just enter y. For debian follow instruction.
- ▶ You will then be prompted again with:  
*Please proceed to 'Software & updates' application to the first tab and set check box 'Officially supported (main)'. Otherwise you will have problems during UCD Console package installation. If you are already done, enter the key 'y'. If not - 'n'*
- ▶ For Ubuntu just enter y. For debian follow instruction
- ▶ Answer y for additional prompts.
- ▶ The Ucd Tool Installer Setup app should now be running.
- ▶ Select *Next>*
- ▶ Select radio button for *Install for all users* or *Install just for me*.
- ▶ You are asked to Choose Installation Directory. Do **NOT** choose the default (`/root/Unigraf/Unigraf UCD Tools` at time of writing). Select a directory that is easy to access and remember.  
  
Note the warning: **Installing in existing directory. It will be wiped on uninstallation.**
- ▶ Select *Next> Install* and *Finnish*.
- ▶ Navigate to the *Unigraf UCD Tools* directory under the installation directory and double click the app you want to run (*UCDConsole.AppImage* for example).

## Firmware Update Procedure

UCD Configuration Utility is used to load an updated firmware to the device. As an option, UCD Configuration Utility can be used to select possible operation roles present in the UCD unit. A firmware set for the selected operation roles is created and the firmware set is programmed to the device. Please contact Unigraf for details.

### Updating from Earlier FW Versions

UCD Firmware versions earlier than 1.8.52 (Pls see Help > About) do not support the procedure described here. Please follow instructions in *Appendix G Firmware Recovery Procedure with Quartus Prime* in this manual.

---

**Note:** Firmware update is a sensitive process. Please do not disconnect the device from the PC and do not power it off before the operation is completed unless specially requested. Avoid plugging and unplugging other USB devices when the firmware update is in progress.

---

To update the firmware or create a new configuration on a UCD-3XX device, please perform the following steps:

- ▶ Connect the UCD unit to a power supply and connect the USB cable.
- ▶ Open UCD Console SW. Select Tools > Open Config Utility update.

The first page of the utility indicates the firmware component versions present in the package. Please click **Next**.

From the list of connected UCD devices please select the one that you want to update. Click **Next**.

---

**Note:** Correct way to update from 2.4 to 3.X. First, enable Advanced mode. Then update all components except MC (which will also be updated in BFBN). Restart the device and UCDCOnfig. Update the MC component. This will avoid the problem with different bootloader (BFBN) versions in 2.4 and 3.X.

---

### Updated Modules

The tool lists the FW components available in the UCD device, the currently programmed FW version, and the FW installed in the PC for programming.

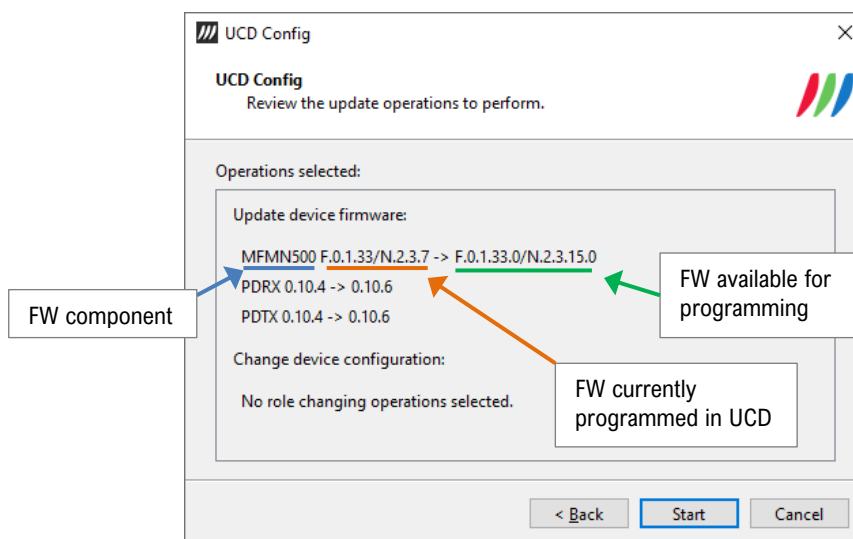

- ▶ Click Start to **start** programming.

### Power Cycle

When re-initiating the firmware of a UCD device the whole process cannot be done during one session. Therefore, on certain point, user is asked to power cycle the device (switch off power from UCD device > wait for 10 seconds > re-apply power to UCD device).

- ▶ Click **OK** button on the dialog.

---

**Note:** The procedure may take several minutes depending on the speed of the USB connection of the host PC.

---

## Firmware Downgrading

The previously released Unigraf SW Bundle 2.4.XX package is not containing UCD Device Firmware (FW). In case UCD device has been installed with the FW delivered with Unigraf 3.X SW Bundle, and version downgrade is needed, also UCD Device Firmware has to be rolled back.

Please follow the procedure below.

1. Download the latest **Console 2 SW Bundle (2.4.XX)** from Unigraf download page at [unigraf.fi/downloads](http://unigraf.fi/downloads).
2. Run the application **SoftwareBundle\_2.4.XX.exe** in the package to install the package. Please do not launch UCD Console application yet.
3. Download **Console 2: FW Package 2.3.38** from the same download page
4. Run the application **FirmwarePackage\_2.3.38.exe** to copy UCD device FW in a proper folder in your PC
5. Launch **UCD Console**
6. Select **Tools > Firmware Update** to start **UCD Config** utility
7. In UCD Config select **Enable advanced mode**

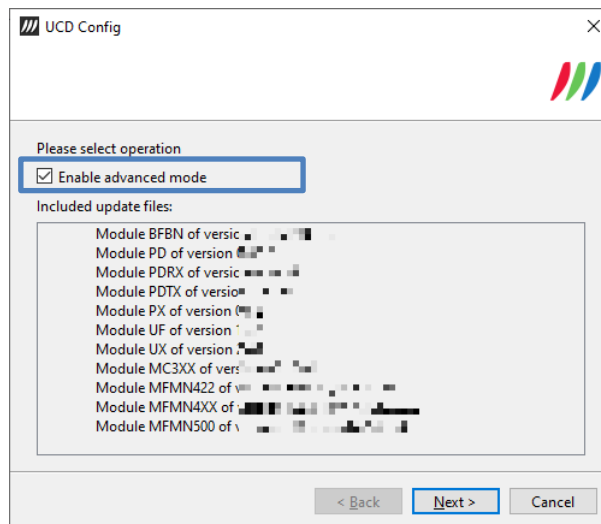

8. Click **Next** to proceed according to chapter *Updated Modules* above.
9. In **UCD Modules** select the module titled MC3XX F.X.X.X/N.X.X.X
10. Click **Next** and **Start** to start programming FW to the connected UCD Device

## Device Roles

The use of UCD-3XX devices with UCD Console is divided in interface specific roles. The structure of UCD Console varies between roles by having a varying set of tabs dedicated to functionalities available in the selected role. The table below lists the roles and tabs available in each role. Please find a detailed description of each role in the later chapters of this manual. Please find a description on changing device configuration later in this document.

### Available Roles UCD-340

Available roles for UCD-340 are USB-C, DP Alt Mode Reference Source and Reference Sink

Roles:
USB-C, DP Alt Mode Reference Source
USB-C, DP Alt Mode Reference Sink

## Change Device Configuration

UCD-300 devices can feature up to four simultaneous Roles. Changing the role configuration is done by selecting the firmware packages loaded to the UCD-300 device. For selecting you need to open UCD Config.

In the first window, select **Enable advanced mode**. Click next.

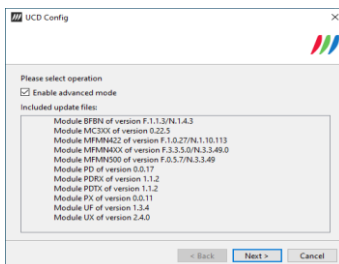

In the second window, select the device you want to configure. Click next.

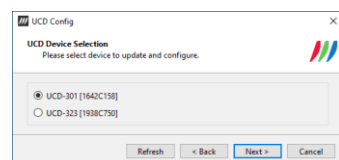

In the third window select MC3XX. Click next.

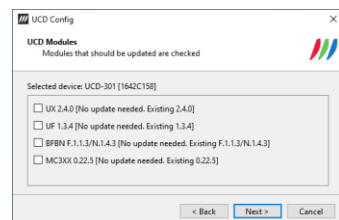

In the fourth window, select the roles for the device. Click next.

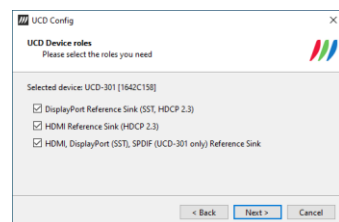

In the fifth window click Start.

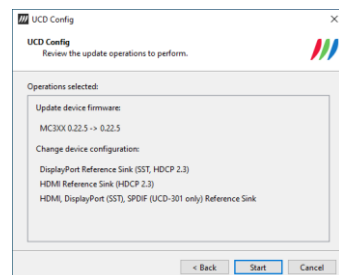

# License Manager

## Licensing

The features of UCD Console GUI are divided into groups based on the target use of the device. Most basic features can be used by default, and more advanced feature groups are enabled by dedicated licenses. When the licenses are present, the related part of the GUI will be shown, or the related control will be enabled.

Unigraf licenses are provided as strings of characters, **License Keys**. Each License Key enables a dedicated function in one device. Each device has its dedicated **Seed Number**. Each **License Key** is tied to one **Seed Number**. License Keys can be freely used in any number of PCs.

License keys are managed with **UCD License Manager**. License manager can be found in the **Tools** menu of UCD Console .

---

**Note:** System administrator's privileges are required for accessing the licenses.

---

## License Manager GUI

When run, License Manager will list the licensing enabled Unigraf devices. In the list of Devices please **Select** the device in question. The *serial number* and the *seed number* of your device are printed in a sticker attached to the bottom of the device.

The **Rescan...** button will re-scan the system for installed hardware.

## Managing Licenses

### Seed Number

Each license is tied to a hardware unit with the help of the **Seed Number**. Each unit has a unique Seed Number. Seed Number of the selected unit can be found in the top of the dialog.

Seed Number of the selected device can be copied from dialog link for e.g., ordering Licenses.

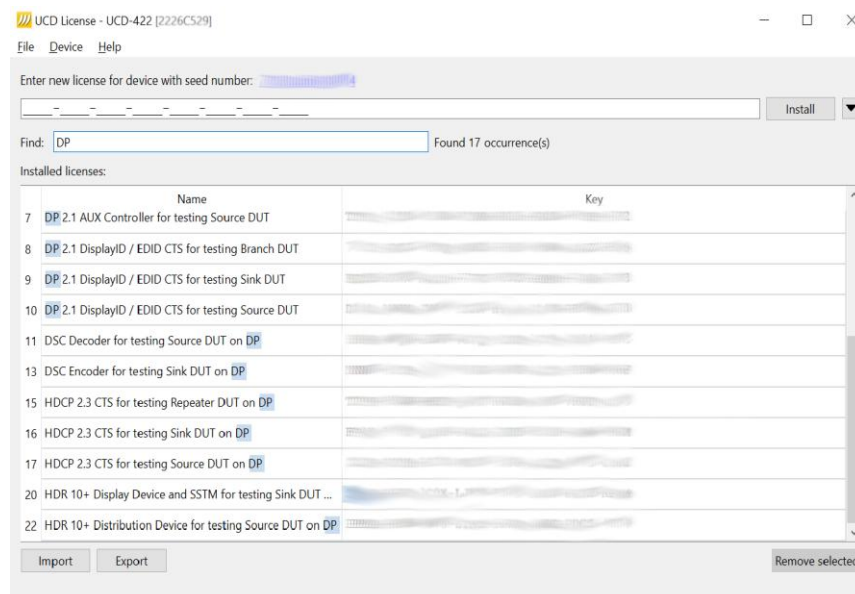

## Adding New License Keys

To add a new license key for a device, please enter the characters from the license sticker to the field for new licenses. The License Manager will automatically move the caret across the edit boxes during typing. If the key is given in text format, copy it and paste to the leftmost box.

Once the license key is fully entered, click the **Install**. The license is authenticated and if it is valid, the license will appear in the list of installed licenses. If the key fails to authenticate, an error message is displayed. If this happens, please make sure that the key has been typed correctly and that the seed number on the license key sticker matches the seed number displayed in UCD License Manager.

Click the Search inverted triangle at the upper right to view the *Find* edit control. Enter a search keyword: The license list is updated to show names that contain the keyword.

Please note that to avoid confusion, some letters will never appear in a license key because they resemble numbers: For example, capital 'G' and number '6' are very similar when printed with small font. When in doubt, use numbers.

Also, please notice, that characters that cannot be part of valid license key are not accepted as input. When appropriate, an automatic conversion is applied while typing: For example, lower case letters are converted to upper case automatically.

## Managing Installed Licenses

The Installed licenses list shows all installed licenses for the selected device. The list shows the name of the license and the actual license key characters.

**Remove Selected** will uninstall selected licenses. To uninstall a license, click on the license and then click the Remove Selected button.

**Export** will allow installed licenses for the currently selected device to be saved into an INI file for backup and distribution to other PCs. To export license(s), click on the license(s) and then click the Export button. Please notice that licenses from multiple devices can be exported into the same INI file.

**Import** will install licenses from an INI file for the currently selected device.

## UCD Console

UCD Console is graphical user interface (GUI) for UCD family test equipment for desktop use. UCD Console provides the user access to all features of the unit. UCD Console also includes powerful debugging and analysis tools enabling the user to monitor the status of the display interfaces and assist in problem detection.

In UCD Console the various features of the UCD unit are divided into interface specific screens and tabs. Each tab contains data and controls for a specific feature.

**Note:** This version of the User Manual describes features in UCD Console software based on the functionality in Microsoft Windows operating system.

UCD Console is also available for macOS operating system to be used in iMac and MacBook computers and for Linux operating system. Detailed description of the macOS and Linux versions will be added later.

## Device Selection

A shortcut of UCD Console can be found by default under Start Menu.

Once UCD Console GUI is launched, the dialog provides a list of Unigraf UCD devices connected in the PC. Please select the target device by clicking on the appropriate button. If your device cannot be found in the list, please confirm the power and USB connection to the device and click the **Rescan ...** button.

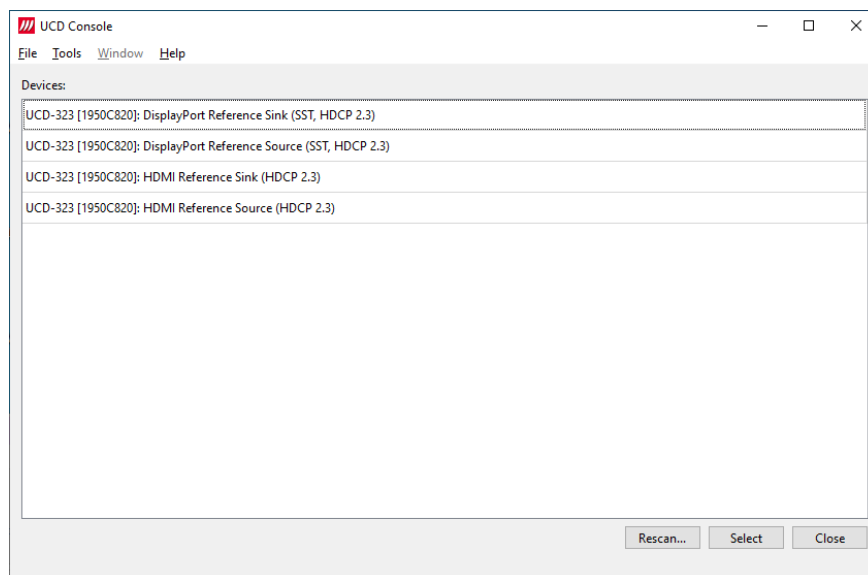

## Analyzer and Generator Operation

Most UCD devices can be used with UCD Console as Analyzer (a Sink device) and as Generator (a Source device). In default configuration UCD-3XX devices can operate in one role at a time.

The operating role is selected when the device is opened in UCD Console. For changing a role, please close the device (File > Close Device), click Rescan ... if needed, and select the new role.

This User Manual will explain all roles available for UCD-3XX devices and the functionalities available for each role.

## UCD Console Menu

### File

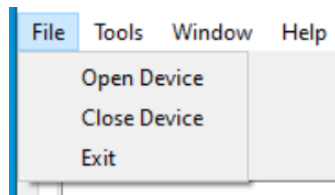

<i>Open Device</i>	Open a device. You can have several UCD Consoles open simultaneously with different devices.
<i>Close Device</i>	Closes device. The device selection window will open.
<i>Exit</i>	Close UCD Console.

### Tools

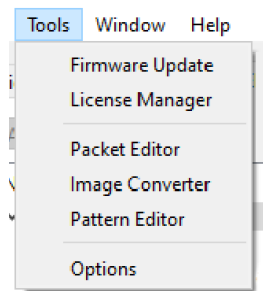

<i>Firmware Update</i>	Open UCD Config for firmware update.
<i>License Manager</i>	Opens License Manager.
<i>Packet Editor</i>	Opens packet editor.
<i>Image Converter</i>	Opens UICL converter.
<i>Pattern Editor</i>	Opens pattern editor.
<i>Options</i>	See below.

## Options

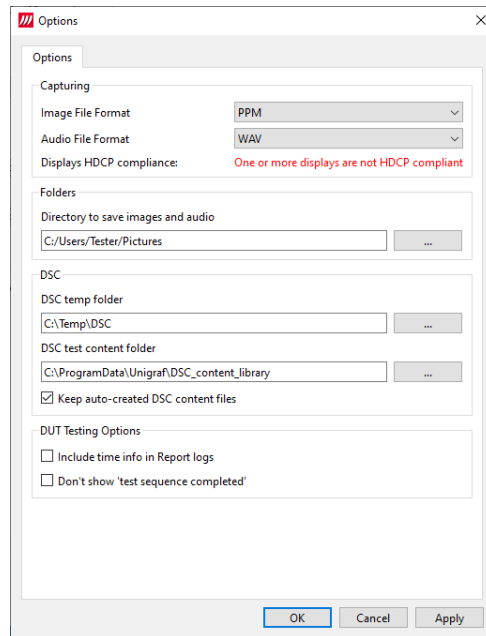

### Image File Format

You can save the captured frames either in PPM, BMP, JPG or PNG bitmap file format. In PPM format the files are stored with the captured color depth, with other formats the color depth is truncated to 8 bits per color.

### Audio File Format

Audio files are stored in WAV format.

### Displays HDCP compliance

Shows if the monitors used are HDCP compliant. Previewing HDCP encrypted content is only possible with HDCP compatible displays.

### Folders

Please select the directories in the PC for saving the captured images and audio.

### DSC

<i>DSC temp folder</i>	Folder for DSC Work files.
<i>DSC test content folder:</i>	Folder where DSC source bitmap files, related configuration files and DSC conversion tools are stored.
<i>Keep auto-created DSC content files</i>	By default, the DSC compressed content is deleted after use. If selected, the content is not deleted

#### Warning

Keeping the automatically created DSC compressed content will shorten the time needed for running the DSC compliance tests.

Please note, that the space needed for storing the full library **can be very large** (appr. 400 GBytes). Please make sure that the content will be stored in a medium that has the required space available.

## DUT Testing Options

<i>Include time info in report logs</i>	Include time info in reports of tests run in Sink / Source DUT testing tab.
<i>Don't show 'test sequence completed'</i>	Don't show dialog after tests run in Sink / Source DUT testing tab.

## Window

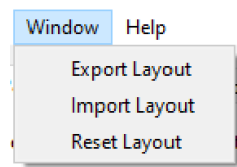

In the window menu you can export and import layout of UCD Console including the tab order. You can also reset layout to factory settings.

## Help

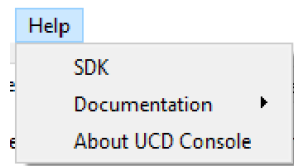

<i>SDK</i>	Opens SDK folder installed during installation of UCD Console. Folder included C, python and test automation scripts
<i>Documentation</i>	Open UCD Console User Manual.
<i>About UCD Console</i>	Show UCD Console information including software and firmware versions.

## Detaching and Cloning Tabs

Most of the UCD Console tabs can be detached into a separate window for monitoring and controlling separate features simultaneously. To detach a tab **Right-click** on a tab and select **Detach Window**. To glue the tab back to the main window, click on the red **Close** button in the top right-hand corner of the window or press **<Alt> + F4** on the keyboard.

Tabs can also be cloned (duplicated) in order to e.g., monitor various areas of DisplayPort DPCD simultaneously without swapping addresses. To clone a tab **Right-click** on a tab and select **Clone Tab** or **Clone and Detach** to the two actions simultaneously.

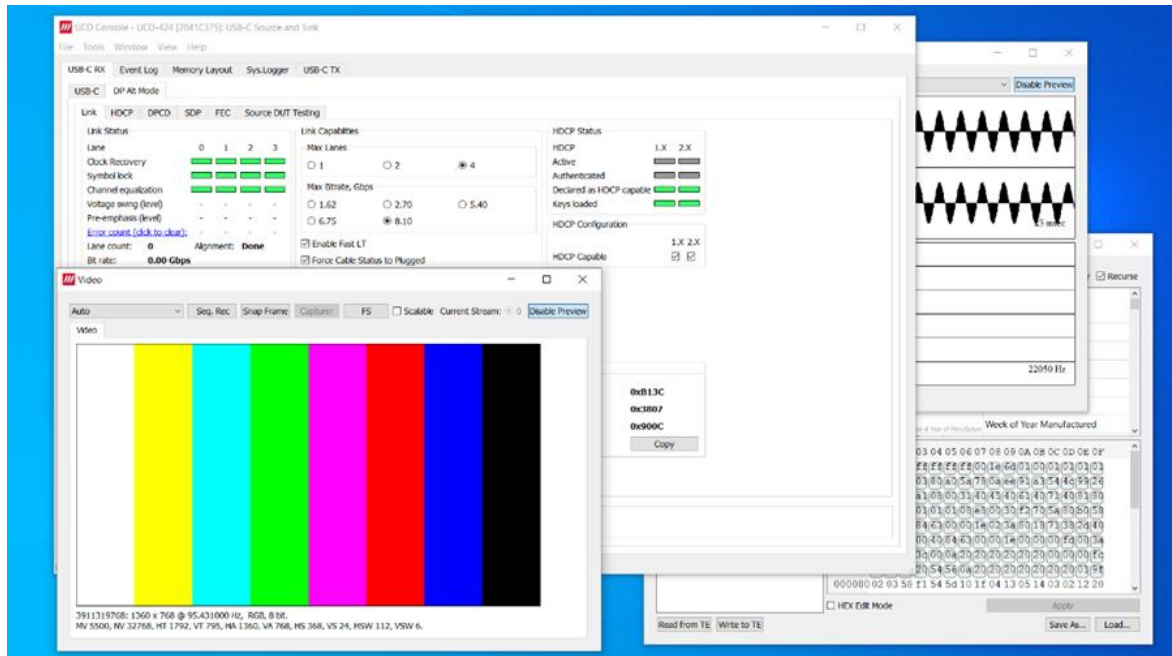

## 4. ANALYZER OPERATION

When used as an *Analyzer*, UCD-340 device acts as USB-C, DP Alt Mode Sink or Receiver devices.

### Functionality Tabs

UCD Console features are presented in tabs. Some of the tabs are enabled by default, some only when an applicable license is included.

Analyzer role features the following tabs:

- Link (Link)
- DPCD (DPCD)
- SDP (SDP)
- AUX Controller (AUX)
- Video preview and saving (Video)
- Capturing video, audio and metadata. (Capture)
- Audio monitoring and saving (Audio)
- EDID editor (EDID)
- HDCP status monitor and control (HDCP)
- Source DUT Testing tab
- Event Log

---

**Note:** Some of the tabs are enabled by default, some only when an applicable license is included. Please refer to Appendix B Licensing of this document for description of features and licensing.

---

# Functionality Tabs

## Link Tab

Link tab shows the status and control items for the DisplayPort link.

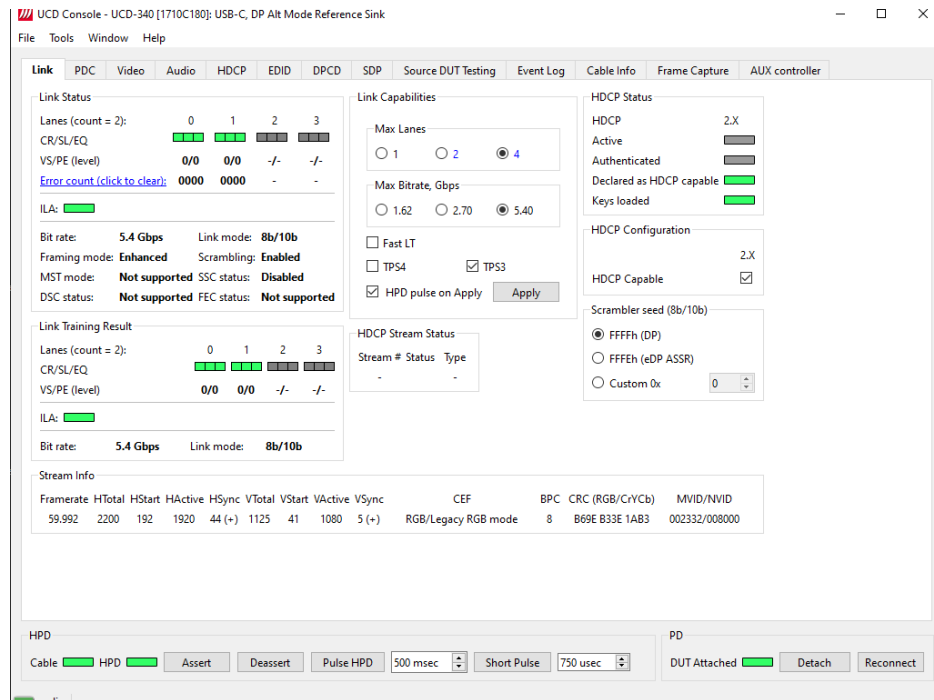

### Link Status

Link Status displays the status of the link training and the link parameters negotiated between UCD Sink and the Upstream Source. It also lists status of other link modes. The data is retrieved from the DPCD status registers of the UCD Sink. The status is updated automatically.

Link Status

Lanes (count = 4):	0	1	2	3
CR/SL/EQ	<span style="color: green;">■</span>	<span style="color: green;">■</span>	<span style="color: green;">■</span>	<span style="color: green;">■</span>
VS/PE (level)	0/0	0/0	0/0	0/0
<a href="#">Error count (click to clear):</a>	0000	0000	0000	0000
ILA:	<span style="color: green;">■</span>			
Bit rate:	5.4 Gbps	Link mode:	8b/10b	
Framing mode:	Enhanced	Scrambling:	Enabled	
MST mode:	Not supported	SSC status:	Disabled	
DSC status:	Not supported	FEC status:	Not supported	

**Lanes:** Indicates the number of lanes used for DisplayPort or DisplayPort Alt Mode.

<b>Lanes:</b>	Indicates the number of lanes used for DisplayPort or DisplayPort Alt Mode.
<b>CR/SL/EQ:</b>	LED indicators for status of Clock Recovery / Symbol Lock / Channel Equalization for each of the four lanes
<b>VS/PE (level):</b>	Voltage Swing / Pre-emphasis level
<b>Error count:</b>	Content of DPCD Error Count registers
<b>ILA:</b>	LED indicator for 'Inter lane Alignment Done'
<b>Bit rate:</b>	Currently enabled link bit rate

<i>Link mode:</i>	Currently enabled channel coding (8b/10b)
<i>Framing mode:</i>	Currently enabled Framing Mode (Normal or Enhanced)
<i>Scrambling:</i>	Status of link data scrambling (Enabled or Disabled)
<i>MST mode:</i>	Not Supported
<i>SSC Status:</i>	Status of Spread-Spectrum Clock (Enabled or Disabled)
<i>DSC Status:</i>	Not Supported
<i>FEC status:</i>	Not Supported

## Link Training Result

The result of the previous Link Training and values of some key parameters.

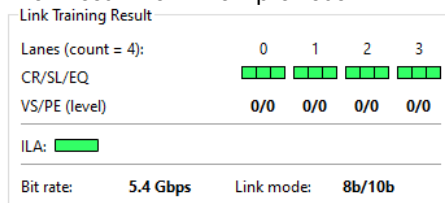

## Link Capabilities

Link capabilities allow the user to change the way the Sink capabilities are announced in the DPCD capability registers of the UCD Sink. Maximum Lane Count and Maximum Link Rate are set with their corresponding radio buttons.

Link Capabilities

Max Lanes:  1  2  4

Max Bitrate, Gbps:  1.62  2.70  5.40

Force Cable Status to Plugged

Enable Fast LT

TPS4  TPS3

HPD pulse on Apply

<i>Force cable status to plugged:</i>	When checked, sink functionality is active regardless of a failure of upstream device detection e.g., due to incorrect AUX Channel electrical termination.
<i>Enable Fast LT:</i>	Indicates support for link training without AUX transactions.
<i>TPS4, TPS3:</i>	Indicate support for Link Training Pattern Sequence 4 and 3 correspondingly.
<i>HPD pulse on Apply:</i>	Select to apply a Hot-Plug Detect (HPD) pulse automatically after updating the status. HPD pulse duration will be defined in the <i>Pulse HPD</i> field in <i>HPD</i> dialog in the bottom of the tab.

To update the new status to the DPCD registers click Apply.

## PD

Shows the status of the DUT. Options to detach and reconnect.

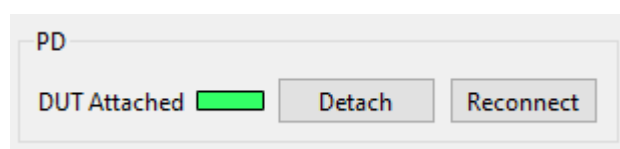

## HDCP Status

Copy of the status from HDCP Tab. Please refer to chapter HDCP Tab later in this document for detailed description.

**Note:** Please note that HDCP 1.3 is not supported in 3.9 release.

## HDCP Configuration

Enable and disable HDCP 1.3 or HDCP 2.3 capability of UCD Sink. Duplicates of the controls found in HDCP tab

## Scrambler seed (8b/10b)

Selection of the value to which the Linear Feedback Shift Register (LFSR) is reset during scrambler reset.

## Stream Info

Video Stream Info are retrieved from the Main-Stream Attributes (MSA) and SDP packets of the monitored stream. Frame rate is measured by UCD Local Sink.

Stream Info												
Framerate	HTotal	HStart	HActive	HSync	VTotat	VStart	VActive	VSync	CEF	BPC	CRC (RGB/CrYCb)	MVID/NVID
59.978	2200	192	1920	44 (+)	1125	41	1080	5 (+)	[VSC] YCbCr4:2:0/ITU-R BT.601	8	B3BC 5699 AFB5	002330/008000

The content of *Stream Info* table can be copied by right-clicking on the table and selecting *Copy*.

<i>Framerate</i>	Vertical refresh rate
<i>HTotal</i>	Horizontal total of transmitted main video stream, measured in pixel count.
<i>HStart</i>	Horizontal active start from leading edge of HSync, measured in pixel count.
<i>HActive</i>	Horizontal active, number of active pixels in video line
<i>HSync</i>	HSync width, measured in pixel count.
<i>VTotat</i>	Vertical total of transmitted main video stream, measured in line count.
<i>VStart</i>	Vertical active start from leading edge of VSync, measured in line count.
<i>VActive</i>	Vertical active, number of active lines in video frame
<i>VSync</i>	VSync width, measured in line count.
<i>CEF</i>	Used color mode: Color format + subsampling / colorimetry. In case of YCbCr formats detailed info gained from VSC SDP.
<i>BPC</i>	Color depth in bits per color (BPC)

<i>CRC</i> (RGB/CrYCb)	16-bit Cyclic redundancy check (CRC) value per color component calculated from active pixels. Value order in YCbCr color format: Cr, Y, Cb.
<i>MVID/NVID</i>	Mvid and Nvid video time stamp values

The MSA information used for Video Timing Details is provided by the Upstream Source, it is not measured by the UCD Local Sink.

## HPD

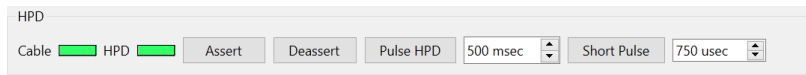

<i>Cable:</i>	LED indicates that the hardware has detected an upstream cable.
<i>HPD:</i>	LED indicates that the HPD signal is Asserted (logical “high”).
<i>Deassert:</i>	Click button to set HPD line to logical “low” (de-asserted) and hence no HPD pulse can be generated.
<i>Assert:</i>	Click to re-activate the HPD line (set to logical “high”).
<i>Pulse HPD:</i>	Click to apply an HPD Pulse with programmable duration. Duration will be defined in the provided field.
<i>Short Pulse:</i>	Click to apply a short pulse. Duration will be defined in the provided field.

## Video Tab

Video tab is the Preview window for the captured video frames.



### Disable / Enable Preview

Click the button to start or stop capturing video frames.

## Video Status

The details of the captured video are presented below the preview window.



08:16.18.397.568.000: 3840 x 2160 @ 60 Hz, RGB 8 bpc, Frame#482.  
 MV 36045, NV 32768, HT 4400, VT 2250, HA 3840, VA 2160, HS 384, VS 82, HSW 88, VSW 10.  
 Live preview frame rate: 0.84 Hz.

First row:	Counter, frame size, frame rate, color mode, color depth, frame counter.
Second row:	Mvid, Nvid, Horiz Total, Vert Total, Horiz Active, Vert Active, Horiz Start, Vert Start, Hor Sync Width, Vert Sync Width.
Third row:	Live preview frame rate.

---

**Note:** Please note that UCD test equipment are able to capture video at full frame rate. *Live preview frame rate* indicates the rate of updating captured video on UCD Console preview screen. Live preview frame rate is limited e.g by the USB communication between UCD test equipment and the PC.

---

## Override Color Detection

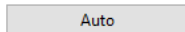

The captured video will be by default automatically converted to RGB 8 bpc for preview and saving based on the information in video metadata.

By clicking Auto button, a dialog opens for overriding the automatic conversion. Captured image data will be interpreted based on the values set in the dialog.

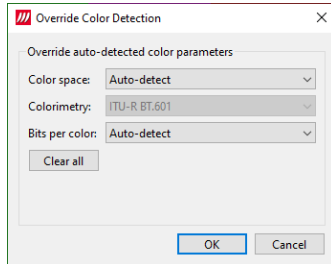

<i>Color space:</i>	Define as which format captured data will be interpreted. (Auto-detect, RGB, YCbCr4:4:4, YCbCr4:2:2, YCbCr4:2:0)
<i>Colorimetry:</i>	Define as which colorimetry captured data will be interpreted. (ITU-R BT.601, ITU-R BT.709, ITU-R BT.2020)
<i>Bits per color</i>	Define as which color depth captured data will be interpreted. (Auto-detect, 6, 8, 10, 12, 16)

---

**Note:** Please note that the color mode selection applies to the preview window only. All internal functions use the raw image data as captured from the input channel.

---

## Frame recording

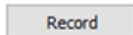

Clicking the button opens a dialog for definition of number of frames recorded.

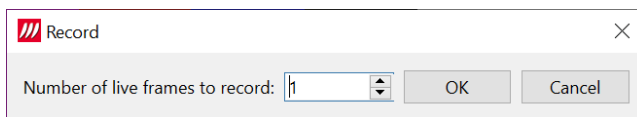

---

**Note:** Please note that buffered mode cannot be used when Audio preview is enabled.

---

## Snap Frame

Snap

When clicked, one frame of the incoming video is captured and shown in a new tab. Each click captures a new frame and opens a new tab.

Color Information of the captured frame can be evaluated by placing the mouse cursor on top of the preview image.

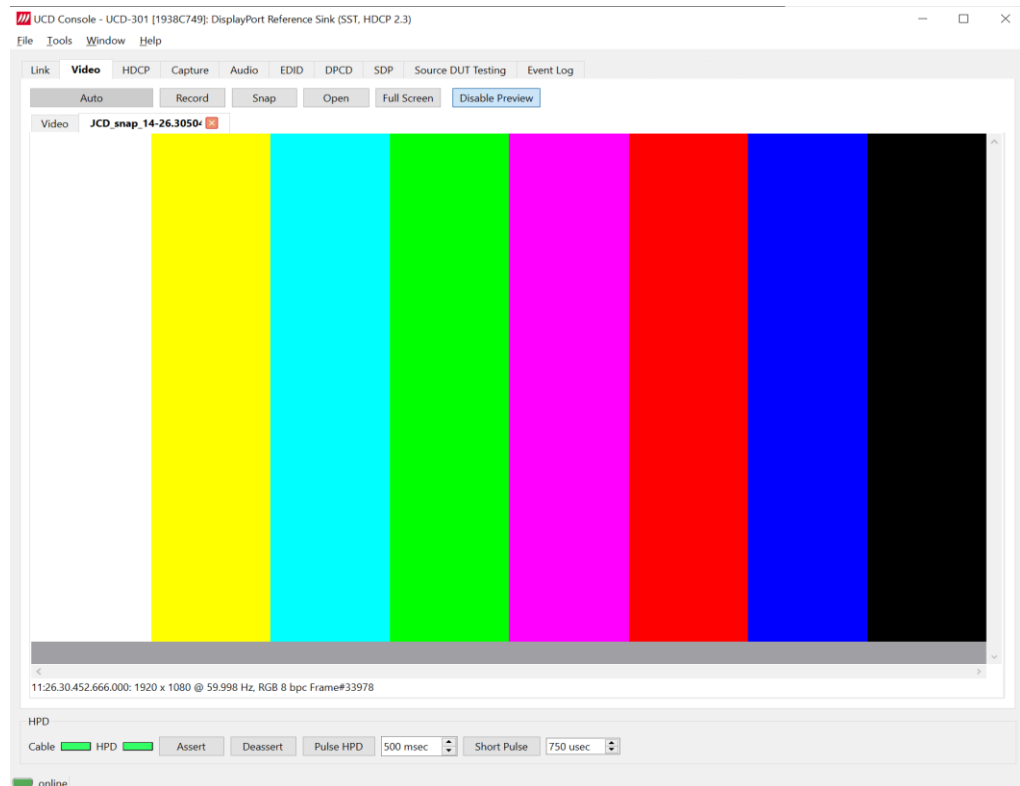

Info field in the lower right side of the bottom panel lists:

- Location of the cross cursor on the bitmap stating from the upper left corner
- The intensity of the color components of the pixel on the cursor location in HEX. Expressed as RGB and YCbCr.

## Zoom

Zoom level of the captured frame can be altered by right clicking on top of the preview image and selecting between

- Fit Window
- Zoom 25%
- Zoom 50%
- Zoom 100%
- Zoom 200%
- Zoom 500%

## Save Frame

The captured frame current tab can be saved to a bitmap file in the PC by right clicking on top of the preview image and selecting **Save as....** The format and storage location can be selected in the opening dialog. The available bitmap formats are BMP, JPG, PNG, and PPM.

---

### Note:

In PPM format the files are stored with the captured color depth, with other formats the color depth is truncated to 8 bits per color.

---

The selections in Tools > Options menu define if the frame bitmap will be stored as captured from the display interface or if the color mode conversion selected for preview will be applied.

## Open

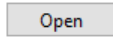

Open folder where captured frames are stored. Double click or click **Open** to select a frame file for viewing. You can select the storage folder in **Tools > Options**.

## Full Screen

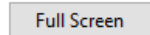

Preview captured video full screen, scaled to vertically fit the screen.

Double-click on the screen or press Esc to exit full screen mode.

## Frame Capture Tab

UCD device has an internal frame buffer that can be used for continuous capture of video data. In addition, audio and metadata can be captured and saved for later analysis. Video can be stored as RGB or RAW data.

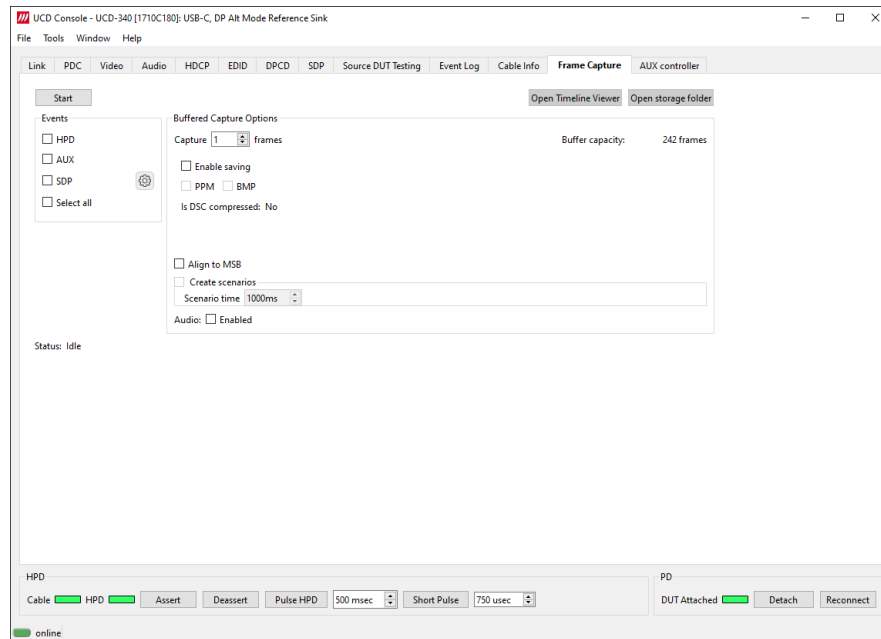

<b>Start / Stop</b>	Start or stop capturing. When capturing <i>Start</i> button label changes to <i>Stop</i> .
<b>Capture N frames ...:</b>	The number of video frames captured.
<b>Format:</b>	Selection of the format of the saved video frame bitmaps. BIN, PPM, BMP, BIN + PPM, BIN + BMP.
<b>Capacity of buffer:</b>	The number of video frames that can be stored to UCD frame buffer using current video signal format
<b>Align to MSB</b>	Store binary data aligned to the Most Significant Bit (MSB). When this is left unchecked, the binary data is aligned to the Least Significant Bit (LSB).
<b>Create scenarios</b>	Define the length of the scenario
<b>Events:</b>	Please refer to chapter <a href="#">Event Log</a> for details of the captured events.
<b>Audio</b>	Enable audio.
<b>Status:</b>	Status of the capture.
<b>Open Timeline Viewer</b>	Open Timeline Viewer to view the captured data.
<b>Open storage folder:</b>	Data save folder is defined in menu Tools > Options. Captured video, audio and data is saved in a subfolder of this folder. The name of the subfolder is "buffered_capture_yyyymmdd_hhmmss" (e.g., buffered_capture_20210301_130532).

---

**Note:** Video Preview needs to be disabled to use Data Capture functionality.

---

## Audio Tab

Audio tab has a preview of the audio signal format and the controls for audio playback and recording. Up to eight channels will be shown based on the received audio stream.

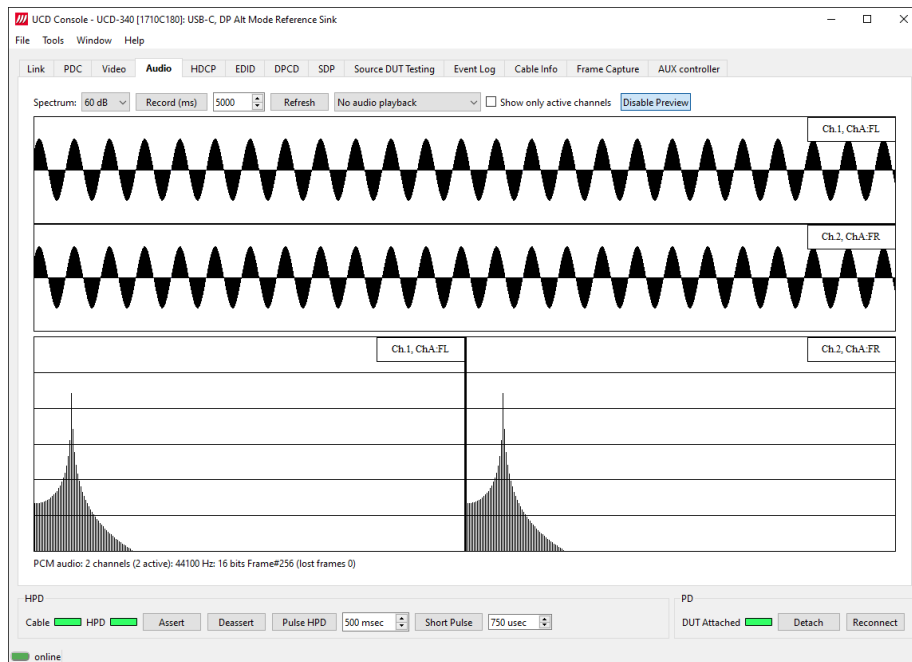

The audio signal format is shown in three ways

- The 'oscilloscope' panel displays the waveforms of the received audio channels.
- The frequency spectrum of the audio is shown in the lower panel. The range of the spectrum display is from 0 to 1/2 of the input sampling rate. The amplitude scale of the spectrum display can be selected between 'Linear' to 100 dB.

The span of the oscilloscope preview window is defined with **Playback buffer** found in Tools > Options dialog. The value is given in ksamples (1024 samples). The relation between the preview window span in milliseconds (msec) and the value given in *Playback buffer* depends on the sampling frequency. Please do not exceed the *Main buffer* set in the same dialog. Please refer to description of the *Video Audio and Misc Options* earlier in this document.

### Enable Preview / Disable Preview

This button controls capturing the audio data.

### Select Monitored Stream

When Multistreaming (MST) is enabled, the monitored stream can be selected from **Current Stream** selection in the bottom of the dialog.

---

**Note:** Please note that if the captured audio signal is constant, and audio signal frequency and audio sampling rate (e.g. 1000 Hz audio and 32 KHz sampling) match audio preview sampling rate, the 'oscilloscope' panel will seem static. Signal capture can be verified by ensuring that Frame # below the panels is increasing.

---

## Playback device selection

The captured audio can be played back in the PC. The combo-box defines the audio device in the host PC through which the captured audio is played. By default, *No audio playback* is selected.

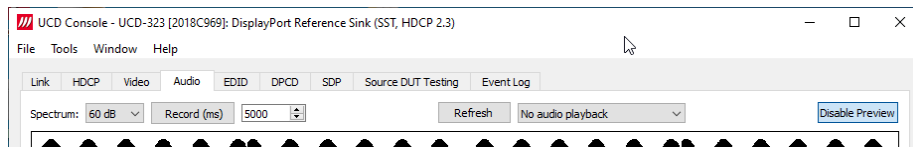

---

### Note:

Please note that the audio capabilities of the audio playback device of the PC are not automatically reflected in the audio capabilities description in UCD-300 EDID. Since UCD-300 is not performing any audio format conversion, it might occur that the source provides an audio format that the selected playback device is not supporting. In case a conflict occurs, please change manually the EDID content, or disable audio playback to monitor the waveforms in UCD Console.

---

## Refresh audio device list

Click here to re-read the list of audio devices after making changes to the host PC configuration.

## Start audio recording

5000

The captured audio can be recorded in the PC using Waveform Audio File Format, WAV (\*.wav) format. Recording duration is defined in milliseconds (ms). The folder where the audio file will be saved can be selected in Tools > Options.

## Input audio mode

2 channels: 44100 Hz: 16 bits Frame#413 (lost frames 0)

This field (in the bottom of the dialog) indicates detected audio mode in the input stream and the number of audio packets captured.

## EDID Tab

EDID Tab provides tools for accessing the EDID and Display ID of the UCD-300 Sink presented to the Upstream Source Device. There are three basic functions:

- Load and save EDID data files in the host PC
- Edit the EDID contents either in EDID Editor or in hex format

### EDID Files

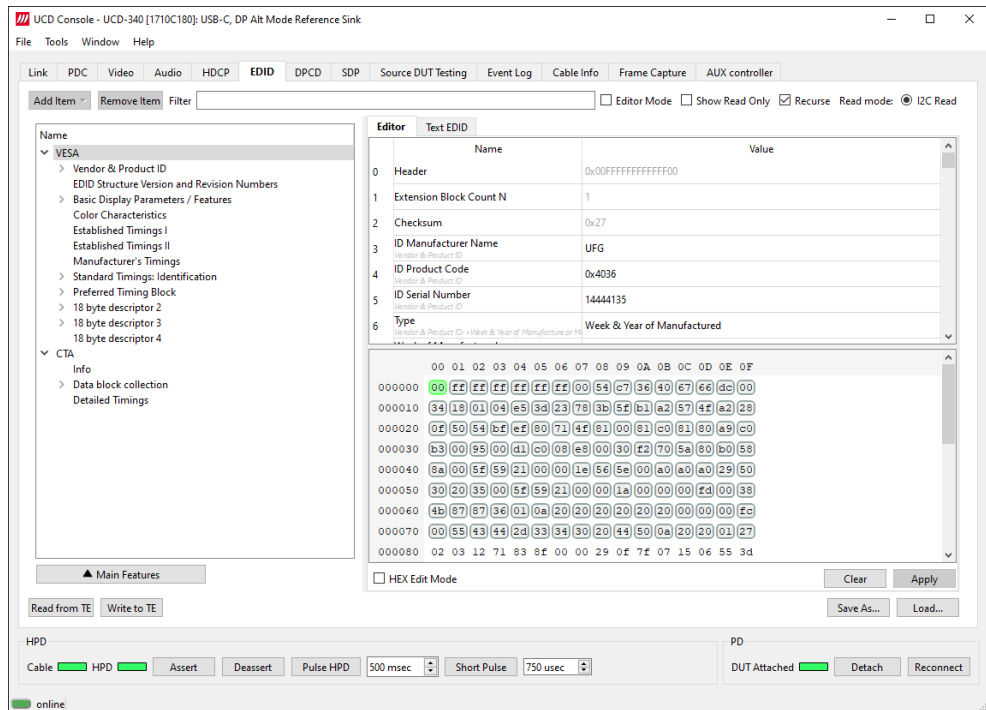

With **Load...** and **Save as...** a hex EDID file can be read and written from the PC. Please note that the program does not alter the contents of the EDID file or verify its integrity during load and save operation.

---

**Note:** Four blocks (512 bytes) of EDID code is read. If the device is not supporting all four blocks, the non-supported area is replaced with blanks.

---

### EDID Editor

Please see the description of the EDID editor in Chapter [EDID Editor](#) later in this document.

## HDCP Tab

HDCP tab is the dialog for monitoring the HDCP (for *High-Bandwidth Digital Content Protection*) status and controlling the HDCP capabilities of the UCD-300 device.

**Note:** Please note that HDCP 1.3 is not supported in 3.9 release.

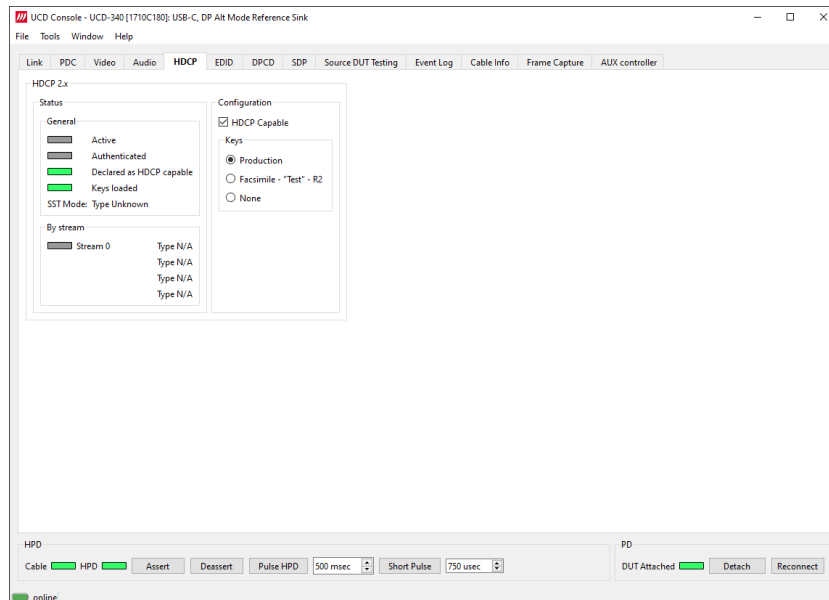

### Status

The status field indicates the HDCP status of the UCD device.

<i>Active:</i>	The link between UCD and the upstream source has been encrypted.
<i>Authenticated:</i>	The HDCP handshake between the UCD and the sink unit has been completed successfully.
<i>Declared as HDCP capable:</i>	The UCD unit recognizes HDCP handshake messages.
<i>Keys loaded:</i>	The HDCP keys are loaded to the UCD unit.

### Configuration

<i>HDCP Capable:</i>	To disable HDCP uncheck the box.
----------------------	----------------------------------

### Keys

Select between *Production* or *Facsimile* HDCP keys. To remove the keys, select *None*.

### HDCP 1.3 / 1.4 vs. HDCP 2.3

UCD-3XX devices support by default HDCP 1.3 / 1.4 standard. The functionality for supporting HDCP 2.2 / 2.3 is enabled with HDCP 2.3 Support license

## Source DUT Testing Tab

Please refer to **Appendix E** later in this document for description of the tests available.

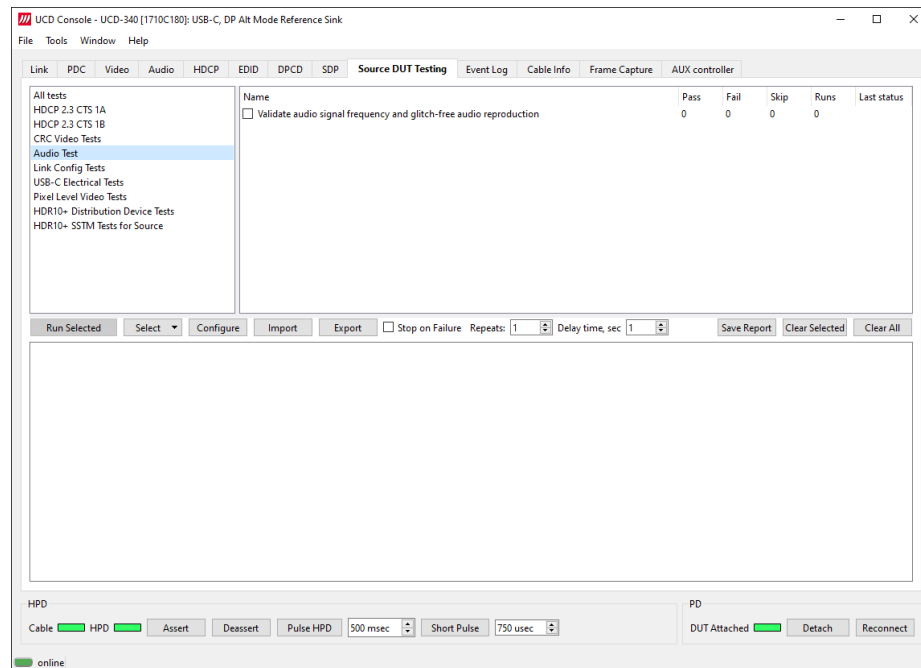

<b>Run:</b>	Run a selected test. You can select a test for running by clicking on the corresponding row. When selected, the row will be highlighted in blue.
<b>Run Checked:</b>	Click to start checked tests. By clicking <i>Abort</i> the sequence is stopped.
<b>Select:</b>	Includes the following options for creating templates for tests execution: Select All, Clear All, Invert All, Save, Import and Export
<b>Configure:</b>	Clicking opens a dialog for defining the test parameters for the selected test set. Please refer to <i>Test Parameters</i> below for details.
<b>Import:</b>	Load saved test parameter files (*.td or *.json).
<b>Export:</b>	Save test parameters for later use or for use in test automation. For saving parameters for later use in UCD Console, either format can be used. For saving parameters for TSI scripting, please use *.td files. For use with Python applications, please use *.json files.
<b>Stop on Failure:</b>	Stops execution of the selected tests if one of the tests fail
<b>Repeats:</b>	Repeat the selected test several times
<b>Delay time:</b>	Delay in seconds between individual tests.

At the completion of each test the result of the test is indicated in the matrix on the right hand side of the test panel. For each test the matrix lists the number of occurrences of each result and the number of tries performed.

<b>Save Report:</b>	Click to generate a HTML report file for sharing the results with other parties for viewing without UCD Console.
<b>Clear Selected:</b>	Clear the results matrix for selected tests
<b>Clear All:</b>	Clear the test log and the results matrix

## Test Parameters

Each test set has its dedicated set of test parameters. To open a dialog for defining the parameters click **Configure**.

Description of parameters for each test set can be found within the description of tests in Appendix E of this document.

## Saving Test Parameters

Test parameters can be saved in various ways.

- Export parameters in *Sink DUT Testing* tab to a \*.td file for later use in UCD Console or with TSI scripting or sharing.
- Export parameters in *Sink DUT Testing* tab to a \*.json file for later use in UCD Console or with Python applications or sharing.
- Save parameters in *Configure* dialog as Presets to be later used in Console. Please find a description below.

## Presets

In all parameter dialogs the selected parameters can be saved as Presets. Please click **Presets...** to save or recall a configuration.

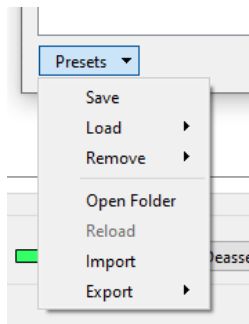

## DPCD Tab

DPCD tab is a tool for monitoring and editing the DPCD registers of the DP Sink.

The *DPCD Decoder* panels on the right show the interpretation of the DPCD byte selected on the monitoring windows. The selected byte is shown with a green background.

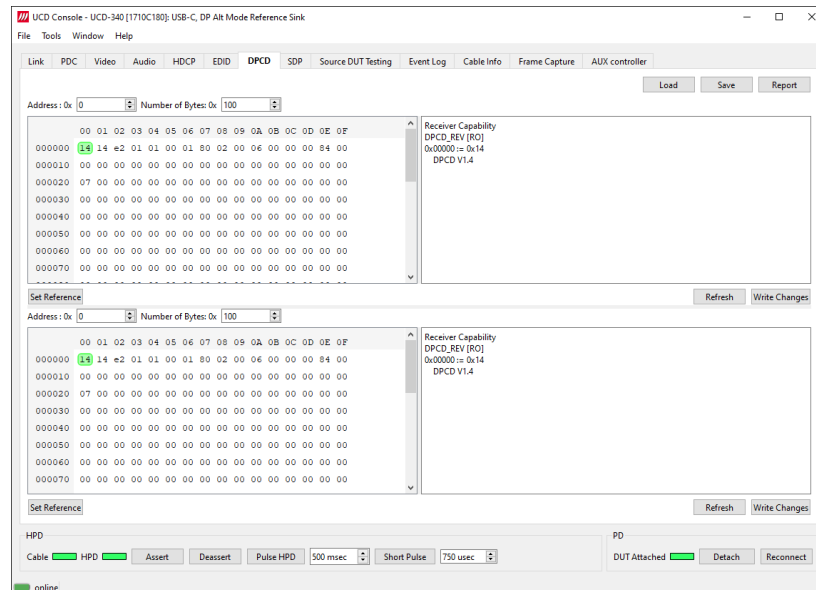

*DPCD Decoder* flags in Tools > Options contain control of DETAILED\_CAP\_INFO\_AVAILABLE flag.

<i>Refresh:</i>	Re-read the data from the DPCD registers to the window in question
<i>Write Changes:</i>	Write the portion of data shown in the window in question to the DPCD registers.
<i>Set Reference:</i>	Store currently shown data as a reference for comparison

When the data is *Refreshed* from the DPCD registers the changed bytes will be highlighted in *blue*. The fields edited by the user will be highlighted in *red*.

### Saving and Loading DPCD Content

DPCD data in the selected address areas can be saved as a file in your PC. There are two alternative formats listed below. Please select the format when saving:

- Binary *DPCD Fata File* format (\*.DPD). This is Unigraf proprietary format. You can also load the DPCD content stored in this format.
- *HEX Dump* (\*.HEX) in a human readable text format.

*Save:* Store DPCD content to a file.

*Load:* Recall DPCD data saved in DPCD Data File (\*.DPD) format to the editor.

## SDP Tab

In SDP Tab shows the *Secondary-Data Packets* sent by the Source device. Click **Refresh** to re-read the data. Show / hide the parsed data by clicking on the arrow in the divider bar.

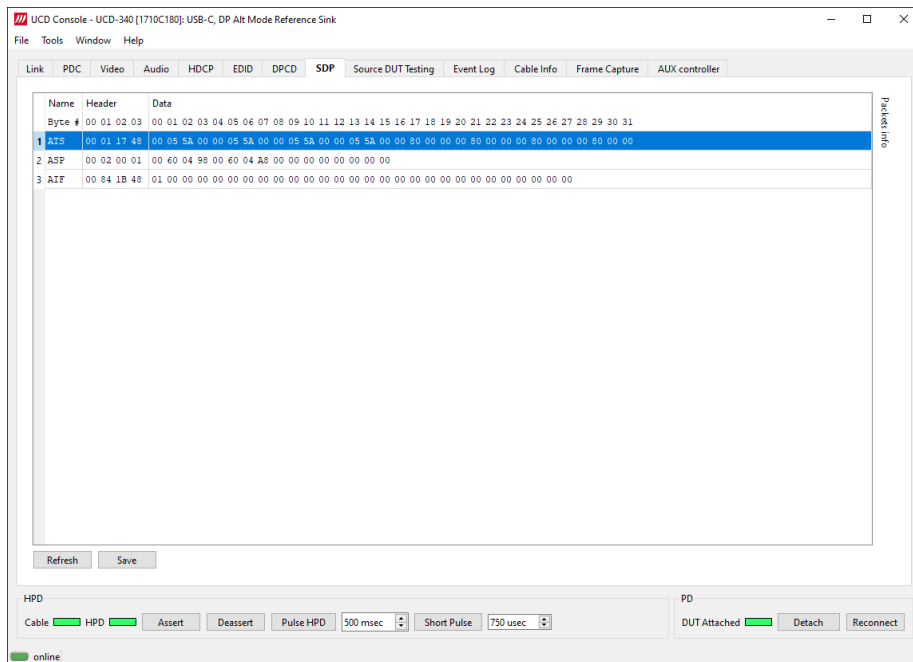

The following packets are recognized:

- Audio\_TimeStamp
- Audio\_Stream
- Extension
- Audio\_CopyManagement
- ISRC (International Standard Recording Code)
- Video Stream Configuration (VSC)
- Camera Generic 0
- Camera Generic 1
- Camera Generic 2
- Camera Generic 3
- Camera Generic 4
- Camera Generic 5
- Camera Generic 6
- Camera Generic 7
- Vendor-Specific Infoframe packet
- AVI InfoFrame packet
- Source Product Descriptor InfoFrame packet
- Audio InfoFrame packet
- MPEG Source InfoFrame packet
- Dynamic Range and Mastering InfoFrame
- Picture Parameter Set (PPS)

## Saving SDP Packets

Packets can be saved in a file in binary format. Click *Save* and in the dialog select the packet types of choice. File name will be of format *ATS\_2022-07-28T15\_54\_24.bin*, where *ATS* is the packet type and *2022-07-28T15\_54\_24* the time stamp.

Saved packets can be evaluated and edited using *Packet Editor*. Please see section *Packet Editor* later in this document.

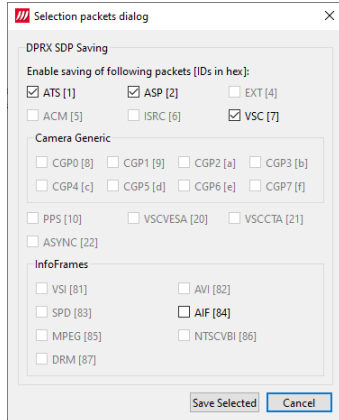

## AUX Controller Tab

AUX controller allows UCD-340 to make Source DUT to train link at a specific link configuration or to output a test pattern. It does this in so-called Routed LT mode in which UCD-340 sends predefined responses to source's AUX requests, ignoring actual main link data.

AUX controller supports both 8b/10b and 128b/132b rates. Link presets are different: VS/PE for 8b/10b and FFE for 128b/132b. Test patterns are also different for 8b/10b and 128b/132b and 128b/132b. Select a 128b/132b rate to see the difference.

Old DP2.0 LT is an older procedure for 128b/132b LT (2-stage instead of new 3-stage LT). It is needed sometimes for debugging

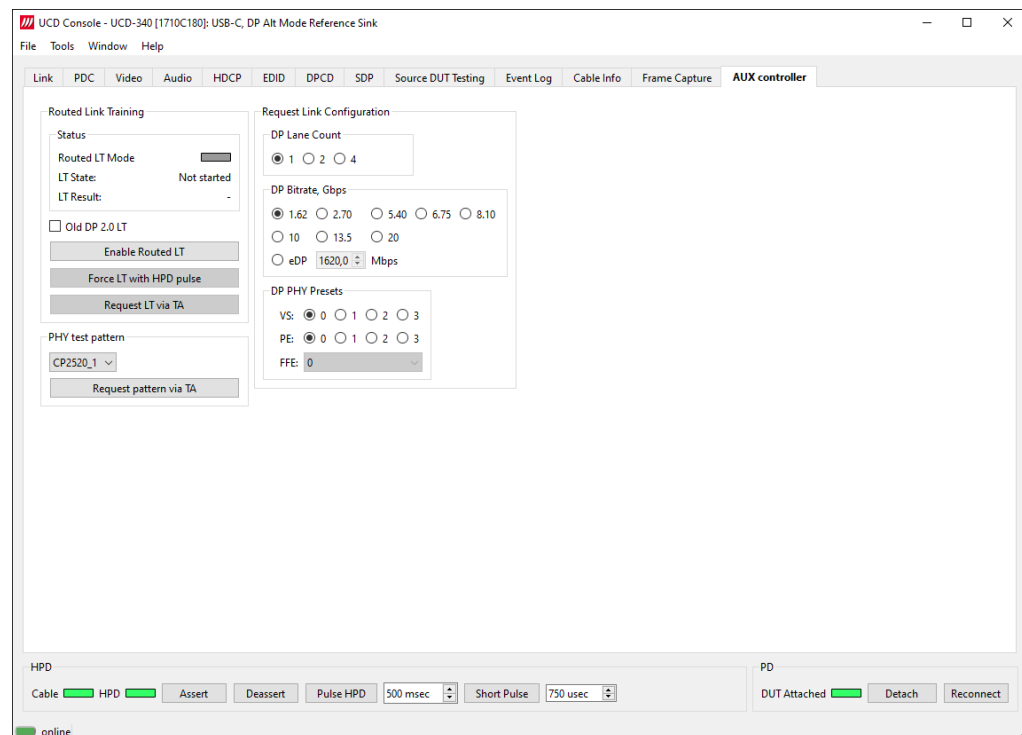

### Routed Link Training

*Status* displays: the *Routed LT Mode* (colored means it is active), the *LT State* (*Not Started* or *Finished*) and the *LT Result* (*Successful* or blank).

Old DP 2.0 LT checkbox lets you do old type 2.0 (128b/132b) link training (see above).

Select *Disable/Enable* button to toggle *Routed Link Training*.

Select *Force LT with HPD pulse* to send HPD pulse and initiate Link Training.

Select *Request LT via TA* to train via test automation.

### PHY test pattern

Select test pattern via combo box:

For 8b/10b: *CP2520\_1*, *CP2520\_2*, *PRBS7*, *SERM*, *TPS1* and *TPS2*.

For 128b/132b: *LTPR CLOCK SWITCH test*, *PRBS11*, *PRBS15*, *PRBS23*, *PRBS31*, *PRBS9*, *SQnum*, *SQnum\_Pre\_Dis\_Post\_Dis*, *SQnum\_Pre\_Dis\_Post\_En*, *SQnum\_Pre\_En\_Post\_Dis*, *TPS1\_128b\_132b*, *TPS1\_128b\_132b*.

Press *Request pattern via TA* to request pattern via test automation.

### Request Link Configuration

Request Link Configuration

DP Lane Count

1  2  4

DP Bitrate, Gbps

1.62  2.70  5.40  6.75  8.10

10  13.5  20

eDP  Mbps

DP PHY Presets

VS:  0  1  2  3

PE:  0  1  2  3

FFE:

Select the desired parameters for Link Training via radio buttons:

<i>DP Lane Count:</i>	Choose between 1, 2 or 4 lanes
<i>DP Bitrate, Gbps</i>	Available options: 1.62, 2.70, 5.40, 6.75, 8.10, 10, 13.5, 20
<i>eDP Bitrate, Mbps:</i>	Set the eDP bitrate in Mbps
<i>DP PHY Presets</i>	VS and PE levels
<i>Pulse HPD:</i>	Click to apply an HPD Pulse with programmable duration. Duration will be defined in the provided field.
<i>Short Pulse:</i>	Click to apply a short pulse. Duration will be defined in the provided field.

### Adjustable AUX voltage swing

Adjustable AUX voltage swing

Enable

Available range: 50..1600 mV

Current swing: 172 mV

New swing, mV:

Select *Enable* checkbox to enable, Choose desired swing in edit control and press *Set* to apply.

---

**Note:** Adjustable AUX voltage swing is only available with UCD-323 Gen2.

---

## USB-C Monitoring

When UCD-340 is used in *DP Alt Mode Reference Sink* role, *USB-C Power Delivery* tab is available. Similar USB-C Power Delivery tab is available also when UCD-340 is used in *DP Alt Mode Reference Source* role.

### USB-C Power Delivery Tab (PDC)

In *USB-C Power Delivery* tab (PDC) operator can evaluate the status of the USB-C connection and USB Power Delivery Contract, the various roles adopted, and the configuration of the DP Alternate Mode. The user can set the initial roles for the UCD-340 test equipment and the optional capabilities for UCD-340 in the PD Contract.

Controls allow user also to swap roles and e.g., use the Cable Swap feature of Unigraf Electrical Test cable.

*USB-C Power Delivery* tab contains a *Status List* and five horizontal tabs for monitoring and configuring the USB Power Delivery Protocol related features of UCD-340.

- Capabilities
- DP Alt Mode
- Power Source
- Power Sink
- Controls
- External Power Load

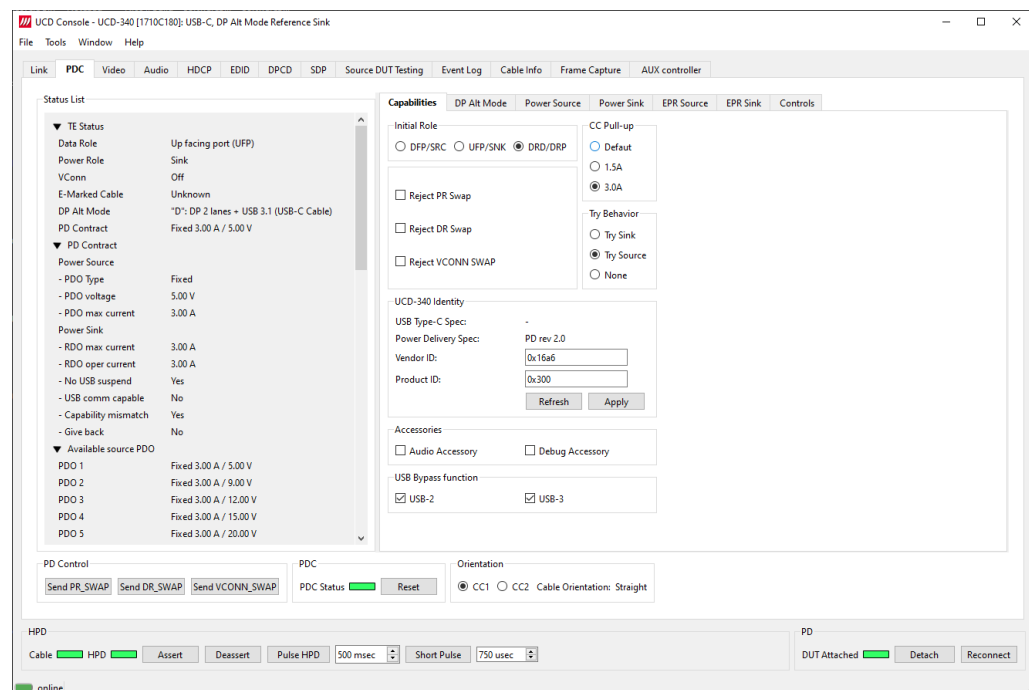

## Status List

In Status List the information is presented in foldable sections. Each section contains information related to one feature of USB-C interface or PD protocol. The user can fold out the sections needed for the task in question.

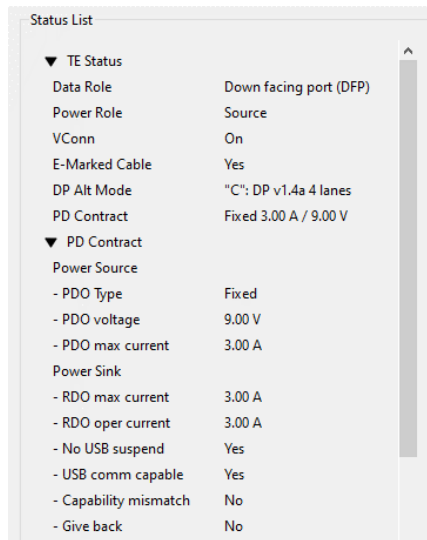



---

**TE Status:** UCD-340 internal status (Data role, Power Role, VConn, E-marked cable, DP Alt Mode, PD Contract status)

---

**PD Contract:** Details of the PD Contract (Power Source: PDO Type, PDO Voltage, PDO max current; Power Sink: RDO max current, RDO operating current, USB statuses)

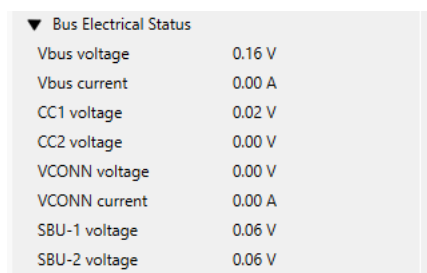
---



---

**Bus Electrical Status:** Vbus voltage and current, CC1 and CC2 voltage, VCONN voltage and current)

---

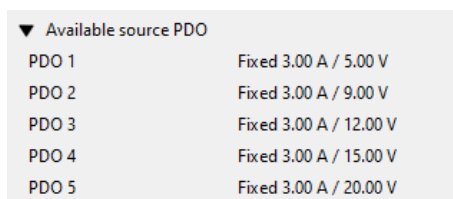

---

**Available source PDO:** PDO1, PDO2, PDO3, PDO4, PDO5

---

▼ DUT Discovery	
Data Capable as Host	N/A
Data Capable as Device	N/A
Product Type	N/A
USB Vendor ID	N/A
USB Product ID	N/A
BCD Device	N/A
SVID0	N/A
SVID1	N/A

**DUT Discovery:** *DUT information (data capable as host, data capable as device, product type, USB vendor ID, USB product ID, BCD device, SVID0, SVID1)*

▼ DUT DP Alt Mode Capabilities	
DP Capable	Unspecified
Receptacle Indication	USB-C plug
USB 2.0 Signaling	May be required
Pin Assignment supported	
- DFP_D	no
- UFP_D	no
- DPAM Version	Version 2.0 or earlier

**DUT DP Alt Mode Capabilities:** *DUT information (DP capability, Receptacle indication, USB 2.0 signaling, Pin assignment support)*

▼ TE DP Alt Mode Status	
Status	Not Active
Multi-function preferred	not relevant
HPD state	de-asserted
DP Capable	N/A
Pin Assignment	N/A
Cable UHBR 13.5 Support	N/A
Cable Active Component	N/A
DPAM Version	N/A
▼ DUT DP Alt Mode Status	
Status	No connection.
Multi-function preferred	N/A
HPD state	N/A
Power low	N/A
No DPAM Suspend	N/A

**TE DP Alt Mode Status:** *UCD-424 internal DP Alternate mode status (Status, Multi-function preferred, HPD state, Select DP v1.3, Select USB gen2, Pin Assignment, Cable UHBR 13.5 Support, Cable Active Component, DPAM Version)*

**DUT DP Alt Mode Status:** *Status of the connected USB-C port partner gained from status update messages (Status, Multi-function preferred, HPD State, Power low, No DPAM Suspend)*

## Capabilities

<i>Initial Role:</i>	Defines the role which UCD-340 presents itself in the start PD communication (both power and data role).
<i>Reject Swaps:</i>	Allow or reject mode swap requests from the connected port partner.
<i>CC Pull-up:</i>	Control of Rp that Source uses to advertise the initial current source capability using USB-C Current method.
<i>Try Behavior:</i>	Control the USB-C PD role that UCD-340 initially takes in the connection handshake.
<i>UCD-340 identity:</i>	Status information provided by UCD-340.

## Accessories

Accessories	
<input type="checkbox"/> Audio Accessory	<input type="checkbox"/> Debug Accessory
USB Bypass function	
<input checked="" type="checkbox"/> USB-2	<input checked="" type="checkbox"/> USB-3

---

*Audio Accessory:* Enable simulation of Audio Accessory support

---

*Debug Accessory:* Enable simulation of Debug Accessory support

---

Enabling *Audio Accessory* and *Debug Accessory* extends USB Type-C Connection State Machine with \*.Accessory states. (Please refer to USB Type-C specification for details).

---

**Note:** Please note that UCD-340 does not support any physical connections for the Accessory functions. The selections enable only behavioral simulation.

---

### USB Bypass Function

Control of data bypass between USB-C connector and USB A and B connectors. Please refer to chapter *UCD-340 > Functional Description* earlier in this manual.

---

*USB-2:* Enable USB-2 data bypass

---

*USB-3:* Enable USB-3 data bypass

---

## DP Alt Mode

Controls and capability settings for DisplayPort Alternate Mode.

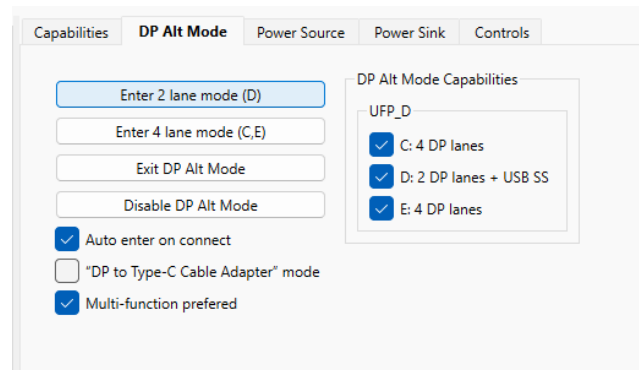

<i>Enter 2 lane mode (D):</i>	Restart mode discovery and advertise support for mode D (2 DP lanes + USB SS).
<i>Enter 2 lane mode (C,E):</i>	Restart mode discovery and advertise support for modes C and D (4 DP lanes).
<i>Exit DP Alt Mode:</i>	Exit DP Alternate mode.
<i>Disable DP Alt Mode:</i>	Exit DP Alternate mode and advertise no DP Alternate mode support.
<i>Auto enter on connect:</i>	Start mode discovery after connection and enter DP Alternate mode if suitable configuration is found.
<i>“DP to Type-C Cable Adapter” mode:</i>	Perform an automated procedure for connecting a DP to USB-C bidirectional cable. Please find an abstract of the issue below.
<i>Multi-function preferred:</i>	When entering DP Alternate Mode, select mode D.

### DP to Type-C Cable Adapter

*USB-C to DP Bi-directional Cable contains an active converter microchip that needs to be powered from USB-C interface. Therefore UCD-340 must be initially configured in power source role for USB Default Operation where it applies vSafe5V on Vbus to power up the microchip in the cable.*

*USB-C to DP Bi-directional Cable uses pin assignment E when acting as a source. In order to provide the “cable” a possibility to request the configuration it needs, UCD-340 has to initiate a Data Role Swap to be in UFP, Device, data mode.*

### DP Alt Mode Capabilities

Supported Pin Assignments declared in DisplayPort Capabilities discover message. Separate for UFP\_D (DisplayPort sink) and DFP\_D (DisplayPort source)

## Power Source

Definition of Power Data Objects (PDO) for UCD-340 when acting as *Power Source Port*.

*PDO Type*: Definition of power source type (Disabled, Fixed, Variable or Battery)

Capabilities								DP Alt Mode		Power Source			Power Sink		Controls	
Source PDOs																
Source PDOs	PDO Type	Max Current, mA	Voltage, mV	Peak Current, %	Max Power, mW	Max Voltage, mV	Min Voltage, mV									
PDO1	Mandatory	3000	5000	150/175/200												
PDO2	Fixed	3000	9000	125/150/200	0	0	0									
PDO3	Fixed	3000	12000	125/150/200	0	0	0									
PDO4	Fixed	3000	15000	110/125/150	0	0	0									
PDO5	Fixed	5000	20000	Default	0	0	0									
Refresh								Apply		Send PDO		Load PDO		Save PDO		

---

**Note:** The requirement is that Sources shall supply at least one fixed supply capable of supplying vSafe5V

---

**Note:** Please note that UCD-340 is not able to simulate as Source the electrical behavior of Variable and Battery source types.

---

**Note:** Please note that External USB-C Power Test Unit is needed to supply 9 V, 15 V and 20 V Vbus voltages.

---

<i>Refresh</i>	Re-read status from UCD-340
<i>Apply</i>	Program new values to UCD-340
<i>Send PDO</i>	Send a Source Capabilities message
<i>Load PDO</i>	Load a stored Power Source PDO configuration from file.
<i>Save PDO</i>	Store current Power Source PDO configuration to a file

## Power Sink

Definition of Power Data Objects (PDO) for UCD-340 when acting as *Power Sink Port*.

### Controls

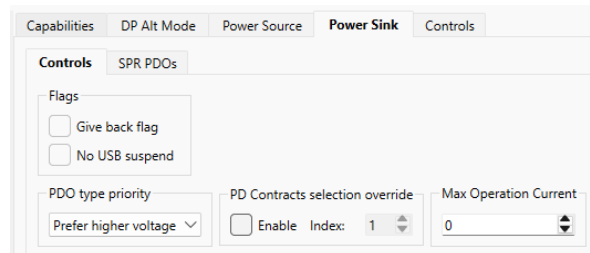

<i>Give back flag:</i>	UCD-340 sets <i>GiveBack</i> flag in its <i>Request Data Object</i>
<i>No USB suspend:</i>	UCD-340 sets <i>No USB Suspend</i> flag in its <i>Request Data Object</i>
<i>PDO type priority:</i>	Setting of the policy used for automatic selection from available PDOs advertised by Source Device. (Prefer higher current / Prefer higher voltage / Prefer higher power)
<i>Max Operation Current</i>	Setting the highest current UCD-424 will ever require when operating as a Power Sink.

**Note:** Please note that UCD-340 is not able to simulate as Sink the true electrical behavior needed for Variable and Battery source types.

### Vbus Load Control

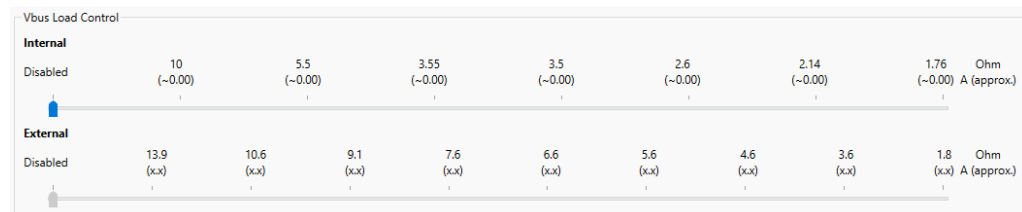

Control of the load resistances affecting the current that UCD-340 sinks from Vbus. The *Internal* load resistances are used when External USB-C Power Test Unit is not present. When External USB-C Power Test Unit is connected to UCD-340 *External* resistors will be used.

Please see UCD-340 Vbus voltage source capability in the table below. Without *Unigraf External USB-C Power Test Unit* UCD-340 is able to source only 5 V.

Vbus power source capability	5 V				9 V	12 V	15 V	20 V
	0.5 A	0.9 A	1.5 A	3 A	3 A	3 A	3 A	5 A
UCD-340	•	•	•	•				
UCD-340 with Eternal Power Test Unit	•	•	•	•	•	•	•	•

**Warning:** When using Unigraf External USB-C Power Test Unit, please make sure that the attached USB-C connection cable is qualified for the current ratings used.

Using a cable that is not qualified for high current will potentially lead to overheating and severe damage.

### Controls (DP Alt Mode Reference Source)

The screenshot shows a software interface with five tabs: Capabilities, DP Alt Mode, Power Source, Power Sink, and Controls. The Controls tab is selected. Under this tab, there are two main sections. The first is 'PD Contract settings', which contains a single checkbox labeled 'Automatically negotiate power contract' that is checked. The second section is 'USB Communication Capable', which contains two checkboxes: 'As PD Source' and 'As PD Sink', both of which are unchecked.

*PD Contract settings:*      *Automatically negotiate power contract:* When selected UCD-340 will start power contract negotiation if suitable configuration is found

*USB Communication Capable:*      You can control the USB Communication Capable bit in its Request Data Object.

## Bottom Panel

Bottom panel includes statuses and controls for the USB-C connection

### PD Control

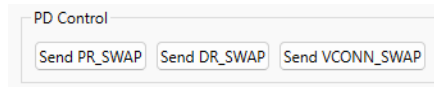

<i>Send PR_SWAP:</i>	Send <i>PR_Swap</i> message to request an exchange of power roles.
<i>Send DR_SWAP:</i>	Send <i>DR_Swap</i> message to request an exchange DFP and UFP operation between Port Partners while maintaining the direction of power flow over Vbus.
<i>Send VCONN_SWAP:</i>	Send <i>VCONN_Swap</i> message to request an exchange of Vconn Source.

### Status

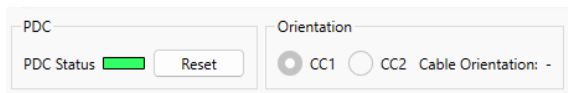

<i>PDC Status</i>	LED for USB-C Power Delivery Control
<i>DUT Attached:</i>	Indication that “ <i>Attach</i> ” is detected by the Source port in one of its CC lines.
<i>Detach:</i>	Manually <i>Detach</i> USB-C port partners.
<i>Reconnect:</i>	Restart USB-C Source-to-Sink attach procedure.
<i>Reset:</i>	Reset the PD Controller in UCD-424 to overcome abnormal situations.
<i>Cable Orientation:</i>	TE CC-line that detected <i>Attach</i> .

## 5. GENERATOR OPERATION

When used as a *Generator* UCD-340 device acts as DisplayPort Alt Mode Source or Transmitter devices.

User is selects device role when opening the Device when launching UCD Console. Selecting *USB-C, DP Alt Mode Reference Source*, UCD Console operates as Generator.

### Functionality Tabs

UCD Console features are presented in tabs. Some of the tabs are enabled by default, some only when an applicable license is included.

Generator role includes the following tabs:

- Link (Link)
- DPCD (DPCD)
- Video pattern generator (Pattern Generator).
- Content Playback (Playback)
- Audio generator (Audio)
- EDID editor (EDID).
- HDCP status monitor and control (HDCP).
- Sink DUT Testing
- Event Log

---

**Note:** Some of the tabs are enabled by default, some only when an applicable license is included. Please refer to Appendix B Licensing of this document for description of features and licensing.

---

# Functionality Tabs

## Link Tab

Link tab shows the status and control items for the DisplayPort link.

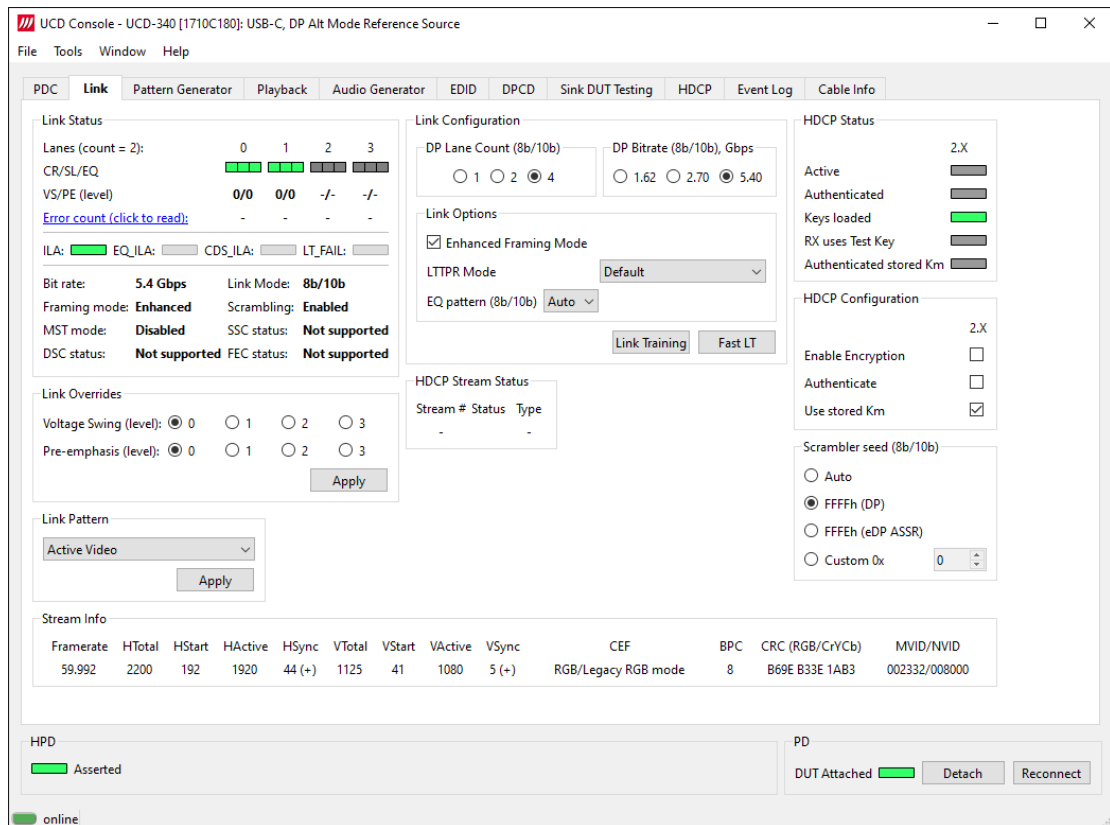

### Link Status

Link Status displays the status of the link training and the link parameters negotiated between the connected Sink and the UCD Source. It also lists status of other link modes. The data is retrieved from the DPCD status registers of the connected Sink. The status is updated automatically.

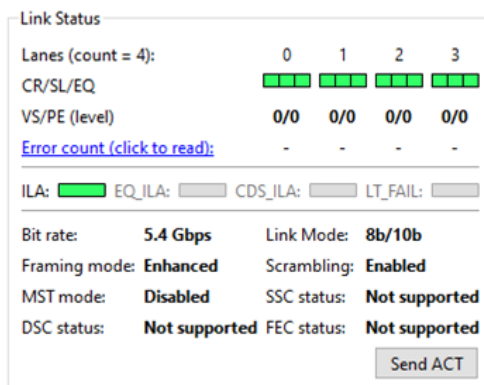

**Lanes:** Indicates the number of lanes used for DisplayPort or DisplayPort Alt Mode.

**CR/SL/EQ:** LED indicators for status of Clock Recovery / Symbol Lock / Channel Equalization.

**VS/PE (level):** Voltage Swing / Pre-emphasis level.

<i>Error count:</i>	Content of DPCD Error Count registers.
<i>ILA:</i>	LED indicator for 'Inter lane Alignment Done.
<i>EQ_ILA:</i>	Disabled with 8b/10b link coding.
<i>CDS_ILA:</i>	Disabled with 8b/10b link coding.
<i>LT_FAIL:</i>	Disabled with 8b/10b link coding.
<i>Bit rate:</i>	Currently enabled link bit rate.
<i>Link mode:</i>	Currently enabled channel coding (8b/10b).
<i>Framing mode:</i>	Currently enabled Framing Mode (Normal or Enhanced).
<i>Scrambling:</i>	Status of link data scrambling (Enabled or Disabled).
<i>SSC Status:</i>	Not Supported.
<i>DSC Status:</i>	Not Supported.
<i>FEC status:</i>	Not Supported.

*Send ACT:* Force sending an Allocation Change Trigger (ACT) sequence over Main-Link.

## Link configuration

Set target capabilities for the link training. Click **Link Training** to apply.

Link Configuration

DP Lane Count (8b/10b)  
 1  2  4

DP Bitrate (8b/10b), Gbps  
 1.62  2.70  5.40

Link Options

 Enhanced Framing Mode  
 EQ pattern (8b/10b) Auto

<i>DP Lane Count (8b/10b)</i>	Lane count used.
<i>DP Bitrate (8b/10b), Gbps</i>	Link rate used .
<i>Enhanced Framing Mode</i>	Enable Enhanced Framing Mode.
<i>EQ pattern (8b/10b)</i>	Pattern (8b/10b) to be used for equalization: auto, TPS2, TPS3,TPS4.

## Link Overrides

Override Voltage Swing and Pre-emphasis selected during link training. Click **Apply** to validate changes. Overrides are applied immediately to DPTX transceiver when 'Apply' is clicked. Please note, that It affects main link signal amplitude and pulse shape only. No AUX exchange takes place. The change can be checked only with a scope. Overrides are removed at the beginning of the next link training.

Link Overrides

Voltage Swing (level):  0  1  2  3

Pre-emphasis (level):  0  1  2  3

## Link Pattern

Select between Active video and audio, Idle pattern, or special bit patterns.

Link Pattern

Active Video
▼

<i>Active Video</i>	Transmit Video Pattern, Audio and Metadata
<i>Idle Pattern</i>	Link is active but no stream data is being transmitted
<i>Training Pattern 1</i>	Send Link Training Pattern Sequence 1 (TPS1)
<i>Training Pattern 2</i>	Send Link Training Pattern Sequence 2 (TPS2)
<i>Training Pattern 3</i>	Send Link Training Pattern Sequence 3 (TPS3)
<i>Training Pattern 4</i>	Send Link Training Pattern Sequence 4 (TPS4)
<i>PRBS7</i>	Send PRBS7 Link Quality Test Pattern
<i>HBR2 Compliance EYE pattern</i>	Send HBR2 Compliance EYE pattern
<i>SER (Symbol Error Rate)</i>	Send Symbol Error Rate Measurement pattern
<i>Force Video</i>	Character error messages from sink will not interrupt video transmission.
<i>Force Idle</i>	Link Training and Active Video will not be initiated even after a re-plug

## Stream Info

Stream Info is retrieved from the Main-Stream Attributes (MSA) of the monitored stream.

Stream Info												
Framerate	HTotal	HStart	HActive	HSync	VTotat	VStart	VActive	VSync	CEF	BPC	CRC	MVID/NVID
50.000	5280	216	4096	88 (+)	2250	82	2160	10 (+)	RGB/Legacy RGB mode	8	3F3A 967D A7BF	008CCD/008000

The content of *Stream Info* table can be copied by right-clicking on the table and selecting **Copy**.

<i>Framerate</i>	Vertical refresh rate
<i>HTotal</i>	Horizontal total of transmitted main video stream, measured in pixel count.
<i>HStart</i>	Horizontal active start from leading edge of HSync, measured in pixel count.
<i>HActive</i>	Horizontal active, number of active pixels in video line
<i>HSync</i>	HSync width, measured in pixel count. (+)/(-) positive / negative sync.
<i>VTotat</i>	Vertical total of transmitted main video stream, measured in line count.
<i>VStart</i>	Vertical active start from leading edge of VSync, measured in line count.
<i>VActive</i>	Vertical active, number of active lines in video frame
<i>VSync</i>	VSync width, measured in line count. (+)/(-) positive v.s. negative sync.
<i>CEF</i>	Used color mode: Color format + subsampling / colorimetry
<i>BPC</i>	Color depth in bits per color (BPC)
<i>CRC</i>	16-bit Cyclic redundancy check (CRC) value per color component calculated from active pixels
<i>VFREQ</i>	Video Frequency (128b/132b channel coding only)

## HDCP Status

Duplicate of the status from HDCP Tab. Please refer to chapter *HDCP Tab* later in this document for detailed description.

**HDCP Status**

	1.X	2.X
Active	<div style="width: 20px; height: 10px; background-color: #ccc; border: 1px solid #000;"></div>	<div style="width: 20px; height: 10px; background-color: #00FF00; border: 1px solid #000;"></div>
Authenticated	<div style="width: 20px; height: 10px; background-color: #ccc; border: 1px solid #000;"></div>	<div style="width: 20px; height: 10px; background-color: #00FF00; border: 1px solid #000;"></div>
Keys loaded	<div style="width: 20px; height: 10px; background-color: #00FF00; border: 1px solid #000;"></div>	<div style="width: 20px; height: 10px; background-color: #00FF00; border: 1px solid #000;"></div>

**HDCP Configuration**

	1.X	2.X
Enable Encryption	<input type="checkbox"/>	<input checked="" type="checkbox"/>
Authenticate	<input type="checkbox"/>	<input checked="" type="checkbox"/>

## HDCP Configuration

Enable and disable HDCP 1.3 or HDCP 2.3 encryption. Duplicates of the controls found in HDCP tab.

---

**Note:** Please note that HDCP 1.3 is not supported in 3.9 release.

---

## HPD

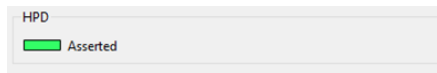

**Asserted:** LED indicates status of Hot Plug Detect (HPD) signal

## Scrambler seed (8b/10b)

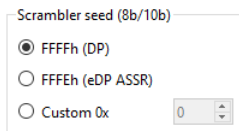

Selection of the value to which the Linear Feedback Shift Register (LFSR) is reset during scrambler reset.

## Pattern Generator Tab

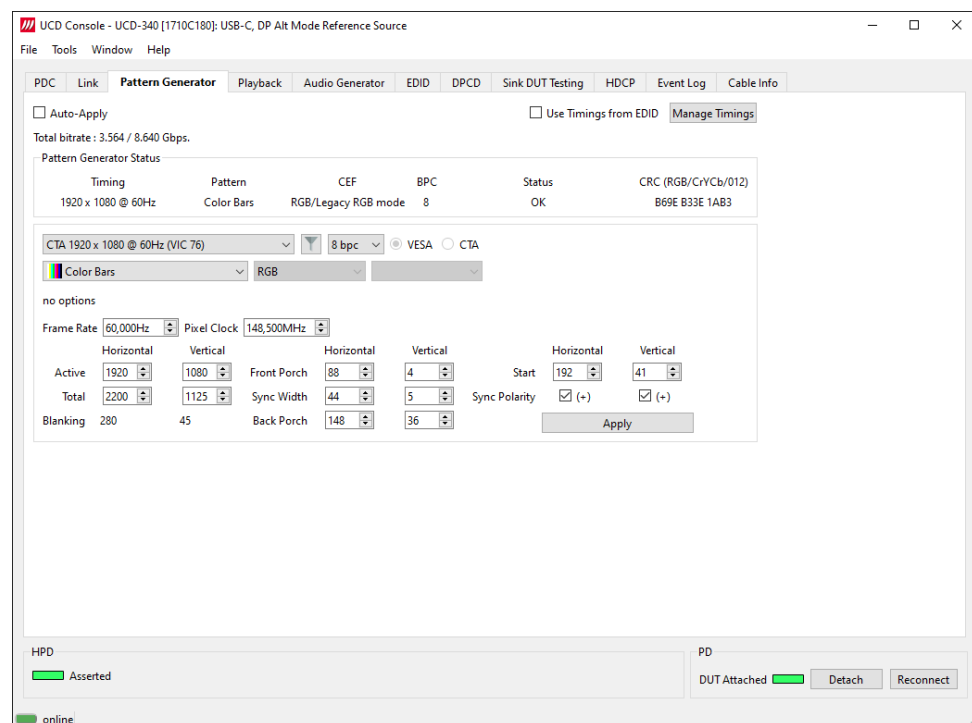

<i>Auto-Apply</i>	In order to avoid sourcing invalid video mode combinations new settings are being validated when the user is clicking Apply. Automatic validation will be applied when <i>Auto-Apply</i> is checked.
<i>Use timings from EDID</i>	UCD reads the EDID of the connected Sink and lists only timings that are featured there.
<i>Manage Timings</i>	Please see chapter <i>Manage Timings</i> later in this manual
<i>Total bitrate</i>	Used link payload / Total link capability in Gbps
<i>Apply</i>	Apply recent changes

## Pattern Generator Status

Pattern Generator Status				
Timing	Pattern	CEF	BPC	Status
1920 x 1080 @ 60Hz	Color Bars	RGB/Legacy RGB mode	8	OK

Pattern Generator Status window shows the current state of the video stream including timing, pattern, CEF, BPC and status.

## Timing and Pattern Controls

Controls include selection of Predefined Timings, Color Depth, Video Pattern and Pattern Options.

### Predefined Timings

The list includes a set of common fixed video timings. Please find a list of the timings with their major details in [Appendix C](#) of this document. With *Manage Timings* function the user can add timings to the list and limit which timings are shown in the selection.

### Filter



Filter timings by specific vendors and resolutions. Click **Enable** to use filters. Timings can be sorted by Vendor ID or width.

### Color Depth

Available color depths are: 6, 8, 10, 12 and 16 bpc. Color depth 6 bpc is only available when using RGB color format in DisplayPort.

### Quantization Range

VESA 8 bits per color ranges transmitted with full color bits: 0 to 255.

CTA 8 bits per color ranges transmitted with limited color bits: 16 to 235.

### Video Pattern

The selection includes a set of predefined patterns and a possibility to load user defined custom patterns. Please find a description of the available predefined patterns in [Appendix D](#) of this document. By selecting **Disabled** you can have the links activated but no video data transferred.

## Custom Image Patterns

BMP, PNG, and JPG files can be loaded from the PC to be used as custom images. The bitmaps will be aligned to the top left corner, displayed at their original resolution, no scaling, cropped to the used active area.

Please refer to *Link Pattern* in description of *DP Reference Source* role *Link tab* later in this manual for sending special binary patterns in the link instead of video.

## Color Mode, Color Depth and Colorimetry

The table below lists the available color modes and related available color depths. Please, note that YCbCr color modes are only available with specific patterns such as color square pattern.

Selection	Color Format	Subsampling	Available Color Depths	Available Colorimetry
RGB:	RGB	4:4:4	6, 8, 10, 12 and 16 bpc	N/A
YCbCr444:	YCbCr	4:4:4	8, 10, 12 and 16 bpc	SMPTE 1 and ITU 709
YCbCr422:	YCbCr	4:2:2	8, 10, 12 and 16 bpc	SMPTE 1 and ITU 709
YCbCr420:	YCbCr	4:2:0	8, 10, 12 and 16 bpc	SMPTE 1 and ITU 709

## Pattern Options

Some of the predefined patterns include additional configuration parameters. The controls for the parameters appear below the pattern selection when the pattern in question has been selected. Please find a description of patterns options in [Appendix D](#) of this document.

## Timing Generator

Generate CTA or OVT timings.

## Timing controls

Frame Rate	60,000Hz		Pixel Clock	148,500MHz	
	Horizontal	Vertical	Horizontal	Vertical	
Active	1920	1080	Front Porch	88	4
Total	2200	1125	Sync Width	44	5
Blanking	280	45	Back Porch	148	36
			Start	192	41
			Sync Polarity	<input checked="" type="checkbox"/> (+)	<input checked="" type="checkbox"/> (+)
					Apply

Users can use the fields to modify the timing details.



## Manage Timings

Custom timings can also be created and edited with pop-up *Timing Editor*. Launch the editor by clicking **Manage Timings**.

## Customizing Timings List

The list of timings that are shown on the pull-down menu in Pattern Generator and Link tabs can be limited by un-checking the check-box in the left edge of *Name* column. The timings will remain in the list and can be brought back to the pull-down menu, when needed.

## Editing Timings

Video timing Name and Description are shown in the list. Lock icon  indicates that a timing is a fixed timing which cannot be edited or deleted. Custom timings are indicated with a head icon .

**New:** Create a new custom timing based on the selected fixed timing.

**Save:** Save changes in the selected custom timing.

The dialog will make a sanity check for the values entered and will warn the user for combinations that cannot be used.

## Playback Tab

Playback allows for running predefined *Playlist* files. Playlist contains a set of *Scenarios* with definitions of the timing, video pattern, audio content and related metadata packets and their duration. You can import playlists by clicking *Import*.

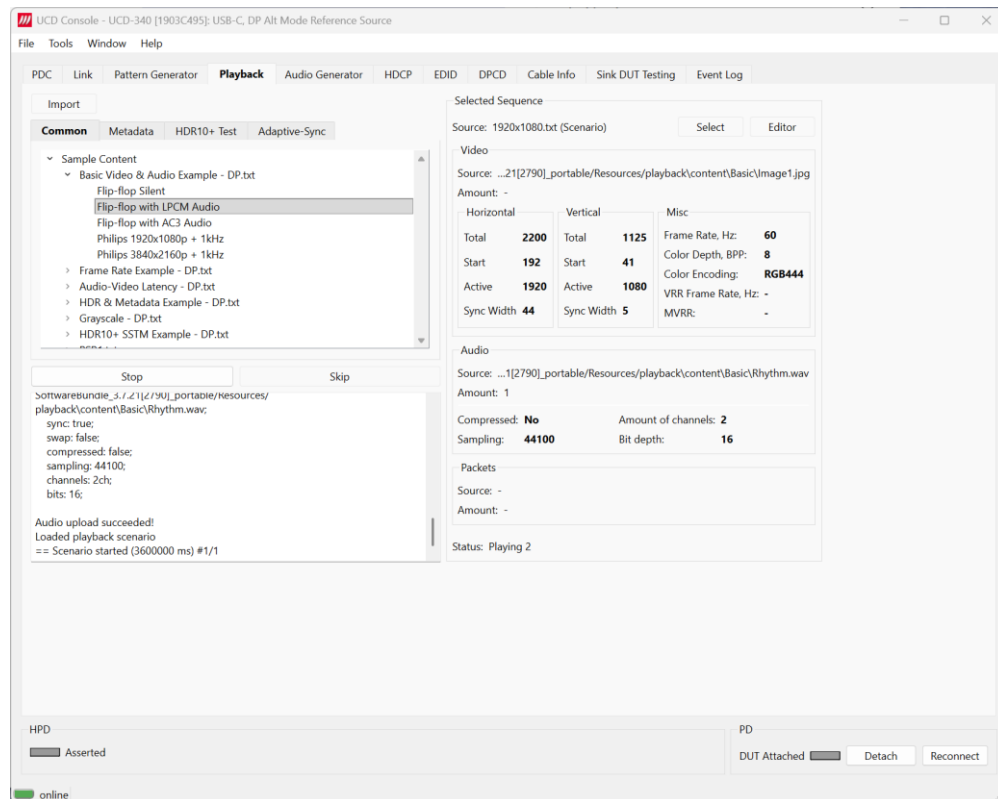

Term	Functionality
Playlist	<i>Playlists</i> (text files) specify the UCD devices and output protocol for transmission. It lists <i>scenarios</i> to be transmitted.
Scenario	Scenarios (text files) allow users to select video frames, metadata packets and audio to be transmitted and their order.
Advanced Playlists	Unigraf UCD devices can be used as compatibility test tools for dedicated standards such as Dolby Vision™ and HDR10+. Contact Unigraf for details.

**Note:** Please note that Playlists and Scenarios are protocol dependent. The provided examples are also somewhat different for HDMI and DisplayPort.

### Common Tab

The *Import* button is for importing \*.json files into the *common* tab treeview. Sample content on windows can be found at C:\Program Files\Unigraf\Unigraf UCD Tools\Resources\playback\basic\_library.json. Be **warned** that once imported, items cannot at present be removed. Actually you can but it involves using *Windows Register Editor* to remove values from (uninstall will not help):

Computer\HKEY\_CURRENT\_USER\SOFTWARE\Unigraf\UCD Console\Playback

Computer\HKEY\_CURRENT\_USER\SOFTWARE\Unigraf\UCD Console\MetadataScenario

Sample playlists are included in UCD Console. Select a sequence (a playlist or scenario) from the *Sample Content treeview* and press *Run* (or double click it) to play.

The *Run* button label changes to *Stop* as a *Scenarios* run. Press *Stop* to stop playing the scenario. Press *Skip* to skip to next scenario (available when there are multiple scenarios in a playlist) while playing. While the *scenario* is loading the *Run* button label changes to *Cancel* to allow cancelation.

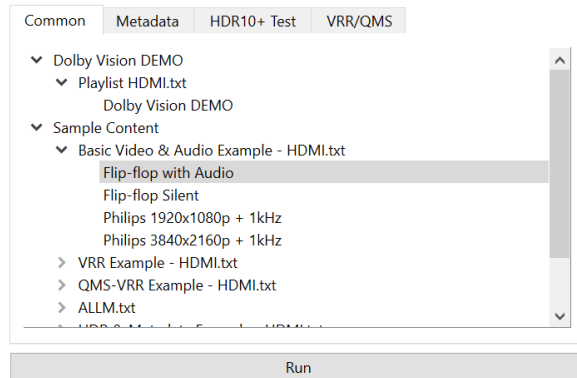

## Status Log

Scenario commands are listed in the *Status Log* as they are run.

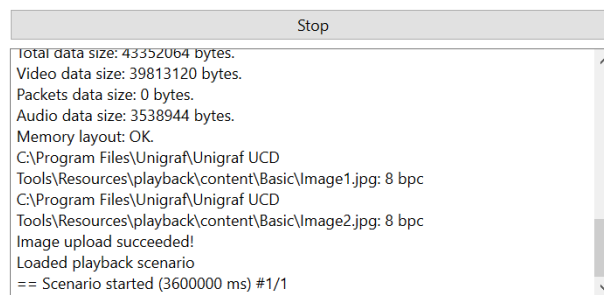

## Selected Sequence

Running scenario video and audio details and their sources are shown in the *Selected Sequence* group panel.

Note that the triggered scenario or playlist to be run is the last selected: If an item was selected via the *treeview*, it is the triggered item to be run. If the *Select* button was used to select an item, it is the triggered item to be run (regardless of what is selected in the tree control).

Press the *Select* button to load a *playlist* or *scenario* to be run (selecting a sample from the *Sample Content treeview* will load them as the *playlist* or *scenario* to be run). It will also be the *scenario* used as a template if the *Scenario Editor* is launched: default scenario values will be set if a playlist is selected.

Press the *Editor* button to launch the *Scenario Editor* (see below).

The *Selected Sequence* group panel displays transmission parameters.

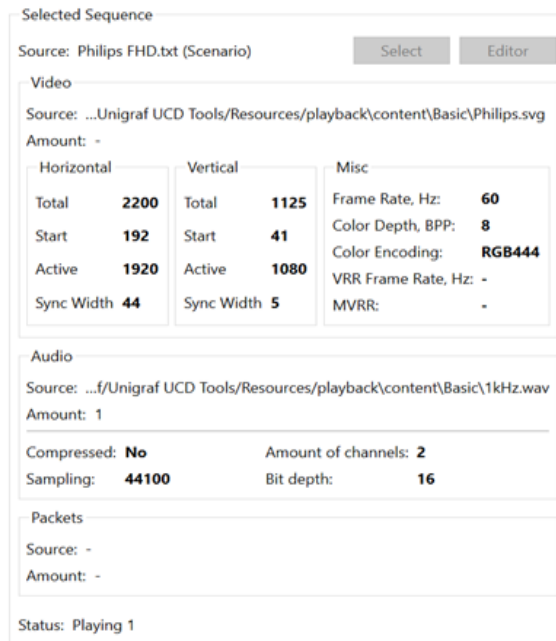

## Metadata Tab

The *Metadata tab* is for creating scenarios with metadata.

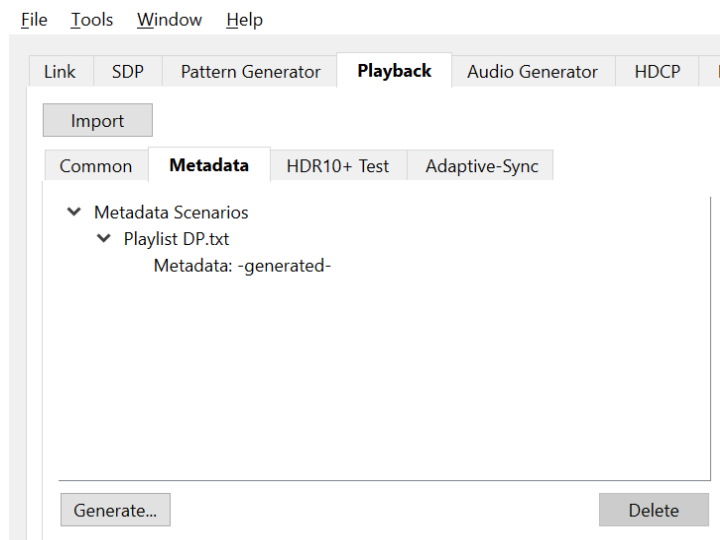

Select the *Delete* button to delete a *scenario* or the *Generate* button to launch the *Custom Metadata Scenario* dialog (shown below).

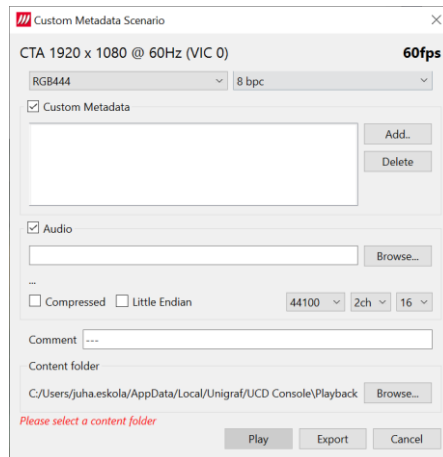

Current *Pattern Generator* timing details are shown at the top (CTA 1920 x 1080 @ 60Hz (VIC 0) above). You can change the color mode (RGB444, YUV444, YUV422, YUV420) and color depth (8 bpc, 10 bpc, 12 bpc, 16 bpc) via the dropdown combo boxes.

Select the *Add* or *Delete* buttons to add or remove metadata from the scenario.

Check the *Audio* checkbox and then the *Browse...* button to add an audio file. Sampling, channels and bits can be selected via the combo boxes.

The *scenario Comment* can be added in line edit box after the three dashes (---).

Use the *Content folder Browse...* button to select save location.

You can press *Play* to run the *scenario*, *Export* to save it or *Cancel* to cancel.

*Export* will create a folder something like Metadata1920x1080@60-RGB444-8bpc in the *Content folder*. In it you will find generated files frame.svg (displayed while running), the metadata files you selected and a scenario.txt file. You may edit and rename these files.

## HDR10+ Test Tab

Please refer to HDR10+ CTS User Manual for detailed description of the tab.

## Adaptive-Sync Tab

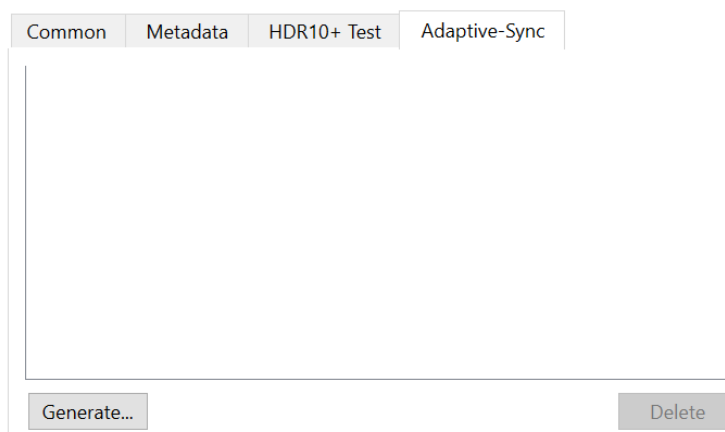

Select *Generate* to generate custom Adaptive-Sync scenarios. Custom Scenario Generator window will open.

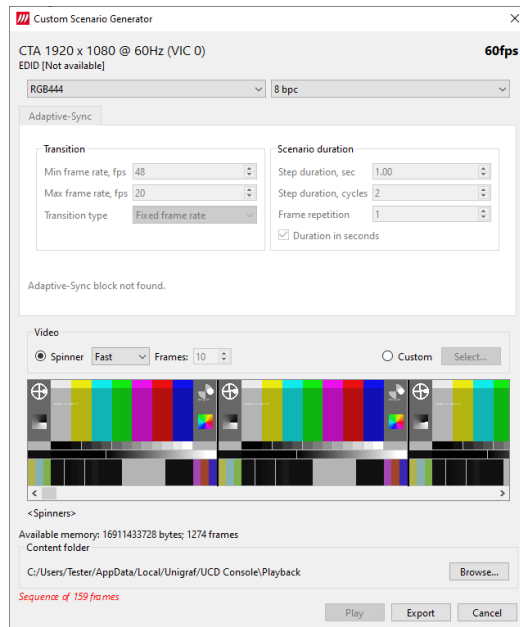

First you are asked to select the folder where the generated content will be stored.

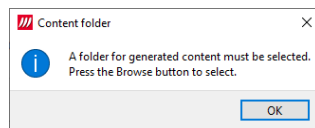

Click *Browse...* to select the folder.

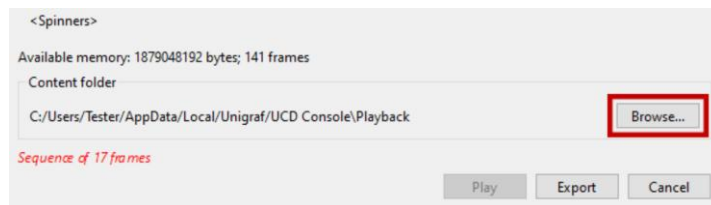

## Adaptive-Sync settings

In the Adaptive-Sync section you can set the transition and scenario duration parameters. Different transition types are Fixed frame rate, Min and max and Gradual.

When *fixed frame rate* is selected, the scenario is played at the minimum frame rate set in the first field. In scenario duration, select how many times frame is repeated.

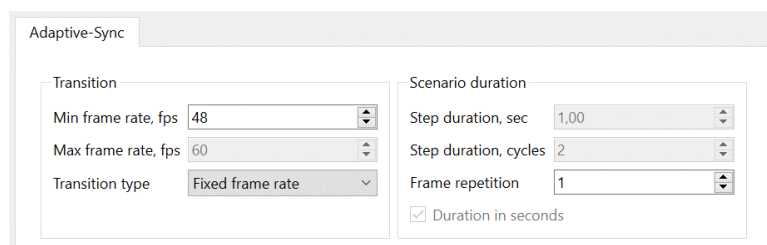

When *min and max* is selected, the output scenario will alter the framerate between the two values set in the drop down menus. You can also set the duration for step in seconds and select how many times frames are repeated.

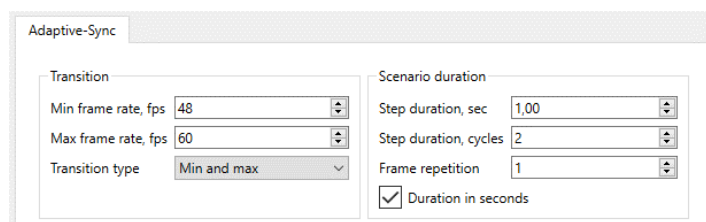

When *gradual* is selected, the frame rate is changed with each frame. For example, when min frame rate is set at 20 and max is set at 60 and the scenario has 40 frames, frame rate would be incremented by 1 with each frame.

Info at the bottom of the segment shows the minimum and maximum values for VRR framerate defined in EDID, and the base frame rate set in the pattern generator.

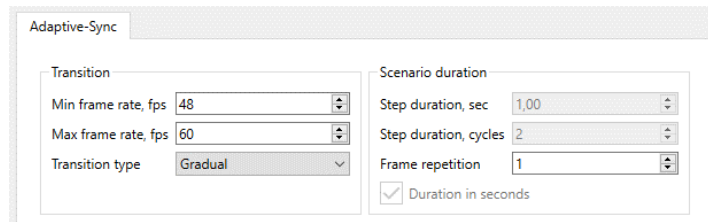

## Video

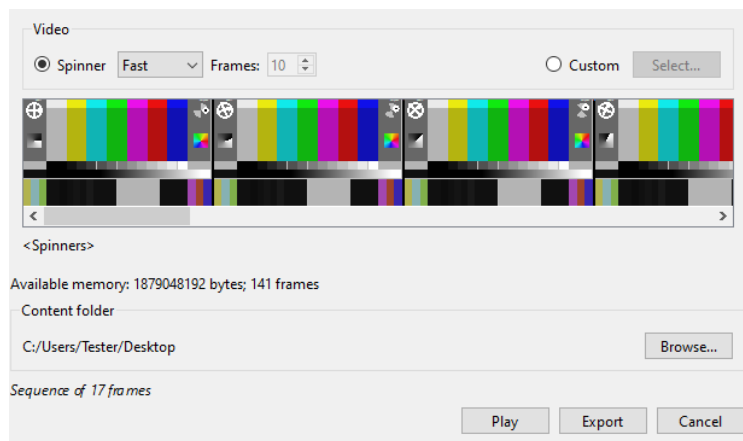

The section at the bottom shows details of the output video. The default pattern is a spinner. You can select the speed of the spinner video from the predefined options in the drop-down menu or you can set a number of frames it takes for the spinner to rotate a full circle. You can also select a custom video. The supported file types are .jpg, .png, .gif, .bmp, .tiff, .ppm and .tif

Available memory is shown in bytes and frames. Below, the folder selected for the sequence is shown. You can change the folder by clicking in *Browse...* Lastly, the duration of the sequence is shown in frames.

You can export the scenario by clicking *Export*. When exporting, you are asked to select a location for the export. The content folder will be automatically created in the chosen location. The folder includes the image files, packets and scenario parameters.

You can play the scenario by clicking *Play*. When the scenario starts playing, the scenario generator window will close. You can now inspect the progress in the log in the palyback tab as shown below.

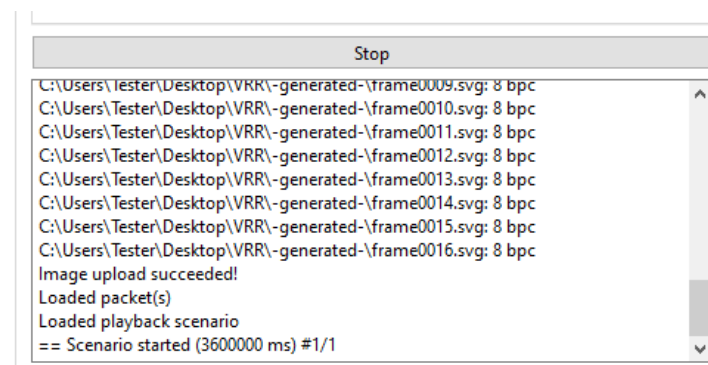

## Scenario Editor

Press the *Select* button (shown above) to select a playlist scenario desired to use as a template for creating a new scenario. Press the *Editor* button to launch the *Scenario Editor*. The the dialog parameters will be generated from the scenario file shown under the panel *Source* label (*Philips FHD.txt* as seen above) or default values if a *playlist* is selected.

Press *OK* to save. You are presented with a save dialog. You need to navigate to a directory you can save to. Run Console 2 with **administration rights** if you want to save to default locations on windows such as: C:\Program Files\Unigraf\Unigraf UCD Tools\Resources\playback\content.

Refer to [Appendix H: Playlists and Scenarios](#) later in this manual for details.

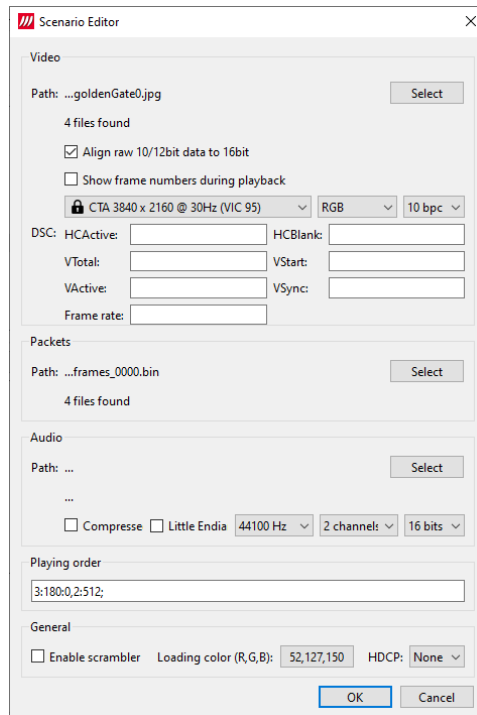

## HDR10+ Test Tab

Please refer to HDR10+ CTS User Manual for detailed description.

## VRR/QMS tab

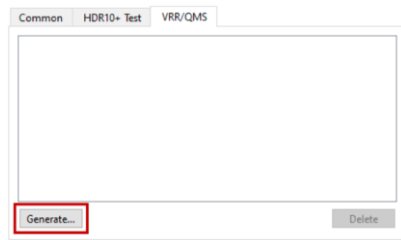

Click *Generate* to generate custom VRR and QMS scenarios. Custom Scenario Generator window will open.

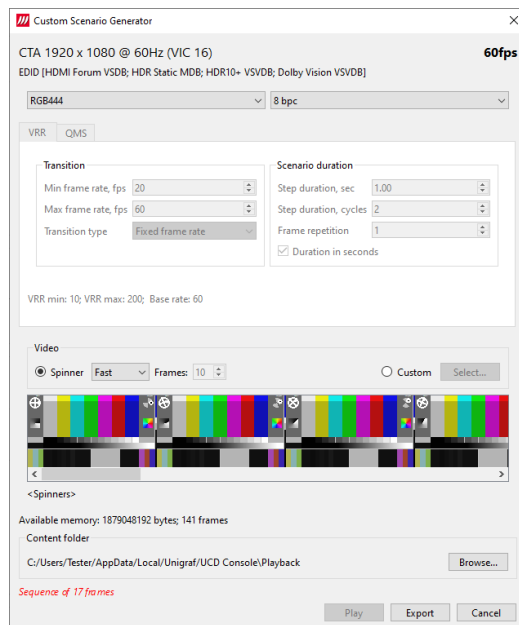

First you are asked to select the folder where the generated content will be stored.

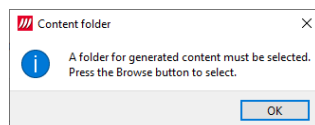

Click *Browse...* to select the folder.

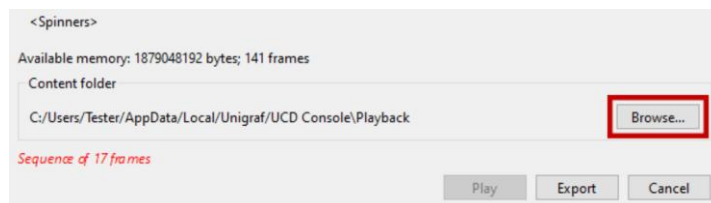

## Timing details

The uppermost part of the window shows the timing details. Please, note that the timing is set on the pattern generator tab. You can change the color mode (RGB444, YUV444, YUV422, YUV420) and color depth (8 bpc, 10 bpc, 12 bpc, 16 bpc).

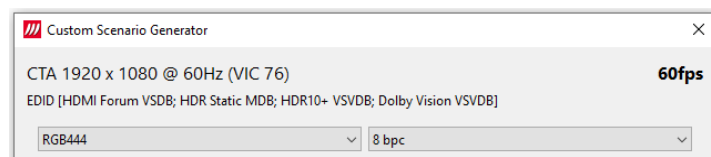

## VRR settings

In the VRR tab you can set the transition and scenario duration parameters. Different transition types are Fixed frame rate, Min and max and Gradual. When *fixed frame rate* is selected, the scenario is played at the minimum frame rate set in the first field. Please, note that when the fixed frame rate is selected, you can only select the number of times the frame is repeated.

The screenshot shows the VRR settings dialog with the 'Fixed frame rate' transition type selected. The 'Min frame rate, fps' is set to 20, 'Max frame rate, fps' is set to 60, and 'Transition type' is 'Fixed frame rate'. Under 'Scenario duration', 'Step duration, sec' is 1.00, 'Step duration, cycles' is 2, and 'Frame repetition' is 1. The 'Duration in seconds' checkbox is checked. At the bottom, it reads 'VRR min: 10; VRR max: 200; Base rate: 60'.

When *min and max* is selected, the output scenario will alter the framerate between the specified values. You can also set the duration for step in seconds and select how many times frames are repeated.

The screenshot shows the VRR settings dialog with the 'Min and max' transition type selected. The 'Min frame rate, fps' is 20, 'Max frame rate, fps' is 60, and 'Transition type' is 'Min and max'. The 'Scenario duration' settings are the same as in the previous screenshot. At the bottom, it reads 'VRR min: 10; VRR max: 200; Base rate: 60'.

When *gradual* is selected, the frame rate is changed with each frame. For example, when min frame rate is set at 20 and max is set at 60 and the scenario has 40 frames, frame rate would be incremented by 1 with each frame.

Info at the bottom of the segment shows the minimum and maximum values for VRR framerate range defined in EDID, and the base frame rate set in the pattern generator.

The screenshot shows the VRR settings dialog with the 'Gradual' transition type selected. The 'Min frame rate, fps' is 20, 'Max frame rate, fps' is 60, and 'Transition type' is 'Gradual'. The 'Scenario duration' settings are the same as in the previous screenshots. At the bottom, it reads 'VRR min: 10; VRR max: 200; Base rate: 60'.

## QMS settings

In the QMS settings dialogue you find all the frame rates included in the QMS specification. Select which frame rates you want to include in your scenario. Also select the step duration in cycles. In the lower left corner details of the scenario as shown.

The screenshot shows the QMS settings dialog. Under 'Next\_TFR', there are checkboxes for various frame rates: 24/1.001, 24, 25, 30/1.001, 30, 48/1.001, 48, 50, 60/1.001, 60, 100, 120/1.001, and 120. There are also 'None' and 'All' buttons. The 'Step duration, cycles' is set to 2. At the bottom, it reads 'SCDC: QMS: 1; QMS-TFRmin: 1; QMS-TFRmax: 1'.

## Video

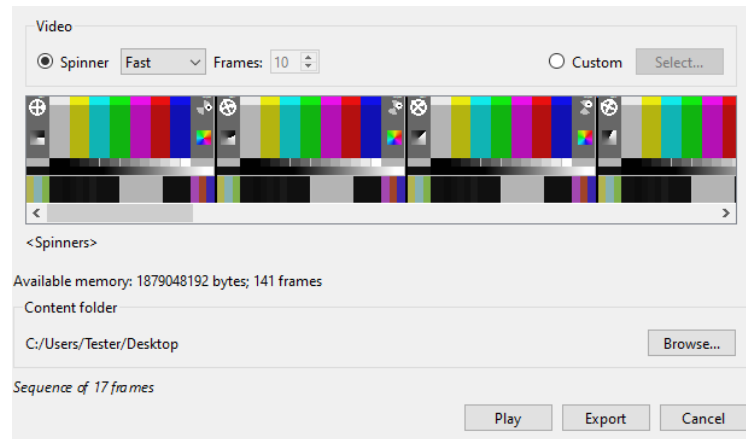

The section at the bottom shows details of the output video. The default pattern is a spinner. You can select the speed of the spinner video from the predefined options in the drop-down menu or you can set a number of frames it takes for the spinner to rotate a full circle. You can also select a custom video. The supported file types are .jpg, .png, .gif, .bmp, .tiff, .ppm and .tif

Available memory is shown in bytes and frames. Below, the folder selected for the sequence is shown. You can change the folder by clicking Browse... Lastly, the duration of the sequence is shown in frames.

You can export the scenario by clicking *Export*. When exporting, you are asked to select a location for the export. The content folder will be automatically created in the chosen location. The folder includes the image files, packets, and scenario parameters.

You can play the scenario by clicking *Play*. When the scenario is ready for playing, the scenario generator window will close. You can now inspect the progress in the log in the playback tab as shown below.

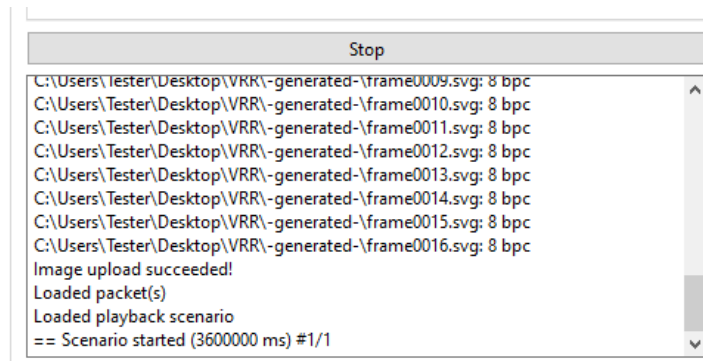

## Audio Generator Tab

Audio generator allows the user to play LPCM audio generated internally or from files in WAV format.

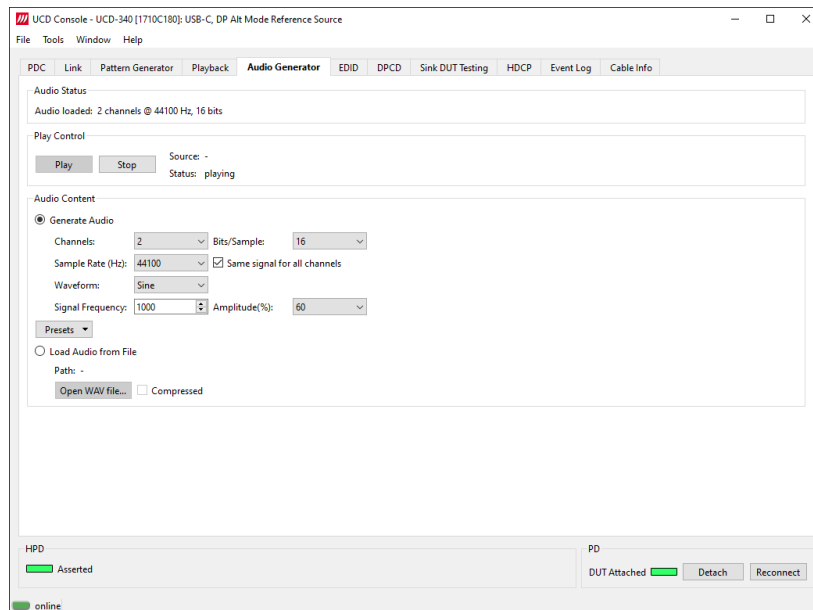

To load internally generated audio, select **Generate audio**, and adjust the controls to the desired audio format.

To load an audio file from your PC, select Load audio from file, click the *Open WAV file...* button, browse and select the file and *Open*.

The *Compressed* checkbox indicates that the audio loaded from the selected file is compressed.

To play the selected audio content, click *Play*.

The content will be transmitted until the *Stop* button is clicked.

*Audio Status* displays current audio content status.

### Audio Content

Sent audio can be generated internally or used a WAV file loaded from the PC.

In case of a WAV audio file, the parameters stored in the file will be used. When generating audio internally, the user sets the details of the LPCM Audio signal.

<i>Channels</i>	Audio channels available: 1, 2, ..., 7, 8. Channels transmit LPCM (uncompressed) Audio.
<i>Sample Rate (Hz)</i>	Selection of audio sampling rate: 32000, 44100 (default), 48000, 88200, 96000, 176400, 192000.
<i>Waveform</i>	Selection of audio waveform: Sine, Sawtooth, Square, or Incremental.
<i>Signal Frequency</i>	Setting audio signal frequency in Hz.
<i>Bits/Sample</i>	Selection of sample bit depth: 16, 20, 24.
<i>Amplitude(%)</i>	Selection of audio amplitude: 10%, 20%, ..., 90%, 100%.
<i>Same signal for all channels</i>	When deselected, you can choose the waveform, amplitude, signal frequency and shift separately for each individual channel

## HDCP Tab

HDCP tab is the dialog for monitoring the HDCP (for *High-Bandwidth Digital Content Protection*) status and controlling the HDCP capabilities of the UCD-300 device.

**Note:** Please note that HDCP 1.3 is not supported in 3.9 release.

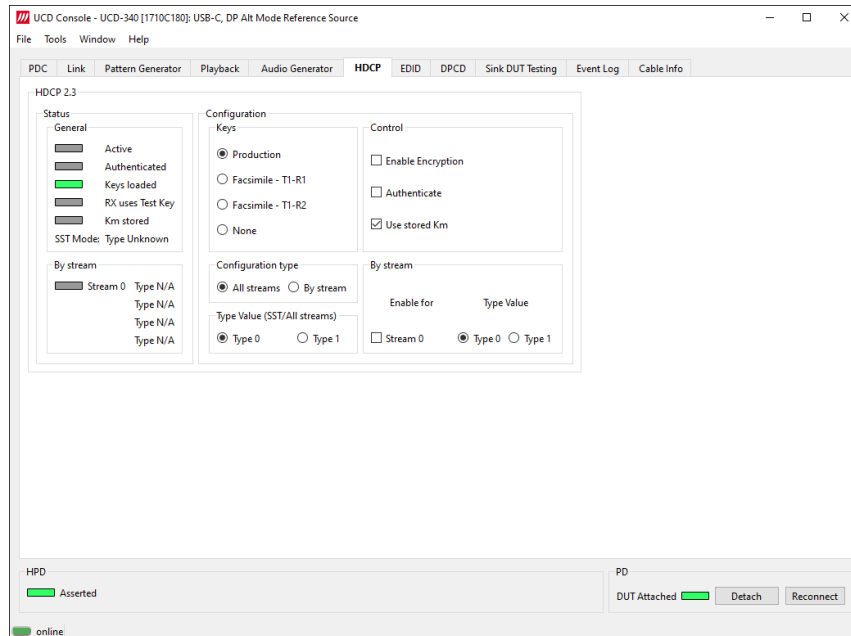

### Status

The status fields indicate the HDCP status of the UCD device.

<i>Active:</i>	The stream between UCD and the downstream sink has been encrypted.
<i>Authenticated:</i>	HDCP handshake between the UCD and the sink unit has been completed successfully.
<i>Keys loaded</i>	HDCP keys are loaded to the UCD unit.
<i>RX uses Test ey</i>	
<i>Km stored</i>	

### Control

<i>Enable encryption</i>	Check to enable the encryption of the stream between UCD and the downstream sink.
<i>Authenticate:</i>	Perform the HDCP initiation handshake between the UCD and the sink unit.

### Keys

Select between *Production* and *Facsimile* HDCP keys. To remove the keys, select *None*.

### Content level

Selection of Type 1 content ensures that content encryption is done with HDCP version 2.2 or higher.

### HDCP 1.3 / 1.4 vs. HDCP 2.3

UCD-300 devices support by default HDCP 1.3 / 1.4 standard. The functionality for supporting HDCP 2.2 / 2.3 is enabled with HDCP 2.3 Support license

## EDID Tab

EDID Tab provides tools for accessing the EDID and Display ID of the connected DisplayPort sink. There are three basic functions:

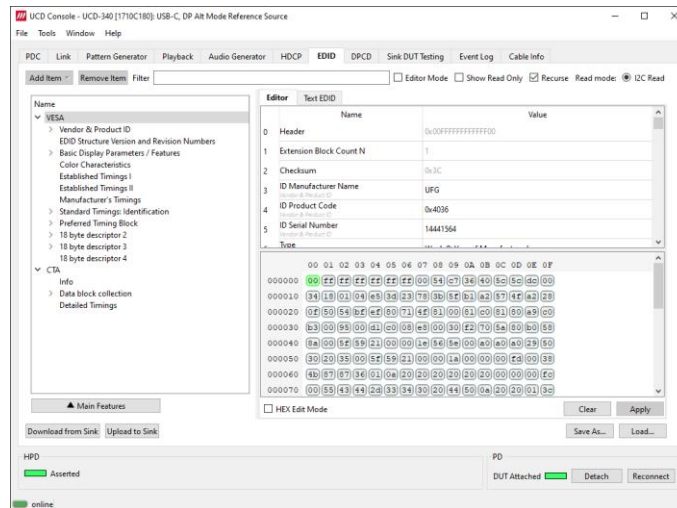

- Load and save EDID data files in the host PC
- Edit the EDID contents either in EDID Editor or in hex format
- Program and read the contents of the EDID of the connected sink

### EDID Files

With **Load...** and **Save as...** a hex EDID file can be read and written from the PC. Please note that the program does not alter the contents of the EDID file or verify its integrity during load and save operation.

---

**Note:** Four blocks (512 bytes) of EDID code is read. If the device is not supporting all four blocks, the non-supported area is replaced with blanks.

---

### EDID Editor

Please see the description of the EDID editor in Chapter [EDID Editor](#) later in this document

## Sink DUT Testing Tab

Please refer to **Appendix E** later in this document for description of the tests available. Sink DUT Testing enables the execution of HDCP 2.3 Compliance Tests for a DP Sink DUT. Sink DUT Testing enables testing of a DP Sink DUT. Please refer to **Appendix E** of this document to get a full definition of the Test Cases and test parameters.

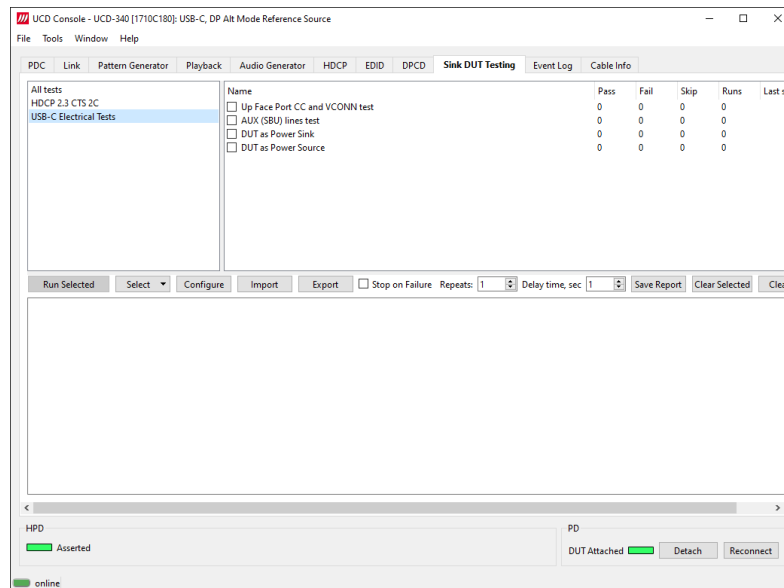

Select the tests for execution by clicking the corresponding row.

<b>Run:</b>	Run a selected test. You can select a test for running by clicking on the corresponding row. When selected, the row will be highlighted in blue.
<b>Run Checked:</b>	Click to start checked tests. By clicking <i>Abort</i> the sequence is stopped.
<b>Select:</b>	Includes the following options for creating templates for tests execution: Select All, Clear All, Invert All, Save, Import and Export
<b>Configure:</b>	Clicking opens a dialog for defining the test parameters for the selected test set. Please refer to <i>Test Parameters</i> below for details.
<b>Import:</b>	Load saved test parameter files (*.td or *.json).
<b>Export:</b>	Save test parameters for later use or for use in test automation. For saving parameters for later use in UCD Console, either format can be used. For saving parameters for TSI scripting, please use *.td files. For use with Python applications, please use *.json files.
<b>Stop on Failure:</b>	Stops execution of the selected tests if one of the tests fail
<b>Repeats:</b>	Repeat the selected test several times
<b>Delay time:</b>	Delay in seconds between individual tests.

At the completion of each test the result of the test is indicated in the matrix on the right hand side of the test panel. For each test the matrix lists the number of occurrences of each result and the number of tries performed.

<b>Save Report:</b>	Click to generate a HTML report file for sharing the results with other parties for viewing without UCD Console.
<b>Clear Log:</b>	Clear the test log and the results matrix

## Test Parameters

Each test set has its dedicated set of test parameters. To open a dialog for defining the parameters click **Configure**.

Description of parameters for each test set can be found within the description of tests in Appendix E of this document.

## Saving Test Parameters

Test parameters can be saved in various ways.

- Export parameters in *Sink DUT Testing* tab to a \*.td file for later use in UCD Console or with TSI scripting or sharing.
- Export parameters in *Sink DUT Testing* tab to a \*.json file for later use in UCD Console or with Python applications or sharing.
- Save parameters in *Configure* dialog as Presets to be later used in Console. Please find a description below.

## Presets

In all *Configure* dialogs the selected parameters can be saved as Presets. Please click **Presets...** to save or recall a configuration.

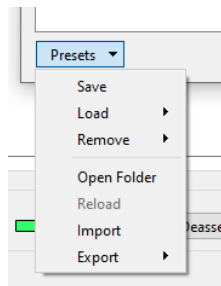

## DPCD Tab

DPCD tab is a tool for monitoring and editing the DPCD registers of the connected DisplayPort or DisplayPort Alt Mode Sink.

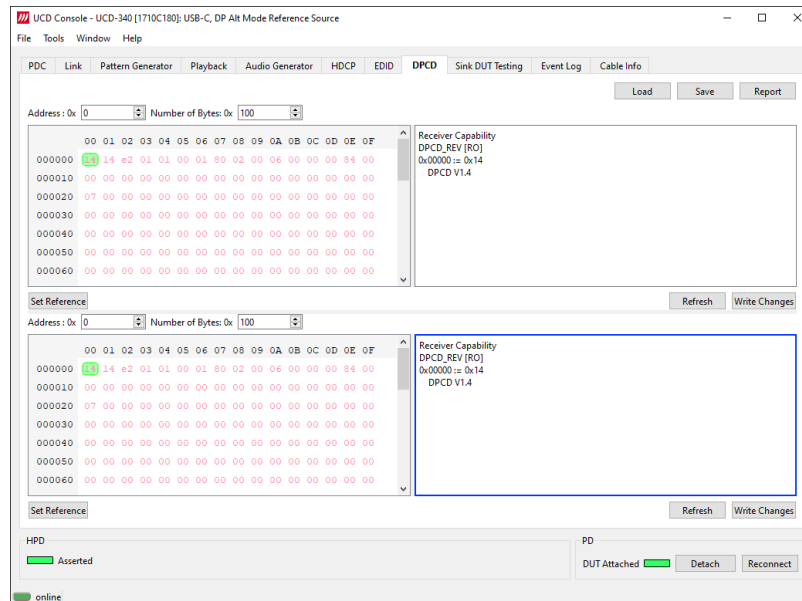

The *DPCD Decoder* panels on the right show the interpretation of the DPCD byte selected on the monitoring windows. The selected byte is shown with a green background.

<i>Save:</i>	Select DPCD content to a binary <i>DPCD Data</i> file (*.DPD).
<i>Load:</i>	Select previously saved binary <i>DPCD Data</i> file (*.DPD).
<i>Report:</i>	Save parsed content of selected DPCD register ranges as HTML file
<i>Refresh:</i>	Re-read the data from the DPCD registers to the window in question
<i>Write Changes</i>	Write the portion of data shown in the window in question to the DPCD registers.
<i>Set Reference</i>	Store currently shown data as a reference for comparison

When the data is *Refreshed* from the DPCD registers the changed bytes will be highlighted with **blue** color. The fields edited by the user will be highlighted with **red** color.

### Saving and Loading DPCD Content

DPCD data in the selected address areas can be saved as a file in your PC. There are three alternative formats listed below. Please select the intended format when saving:

- Binary *DPCD Data File* format (\*.DPD). This is Unigraf proprietary format. You can also load the DPCD content stored in this format.
- *Comma Separated Value* format (.CSV)
- *HEX Dump* (\*.HEX) in a human readable text format.

## USB-C Monitoring

When *USB-C DP Alt Mode Reference Source* role is in use, the following interface specific tabs are available.

- USB-C Power Delivery (PDC)

### USB-C Power Delivery Tab

When UCD-340 is used in *DP Alt Mode Reference Source* role, *USB-C Power Delivery* tab is available. The content of *USB-C Power Delivery* tab is similar to the tab available when in UCD-340 is used in *DP Alt Mode Reference Sink* role.

Please refer to chapter *USB-C Monitoring* in section 4. *Analyzer Operation* earlier in this document

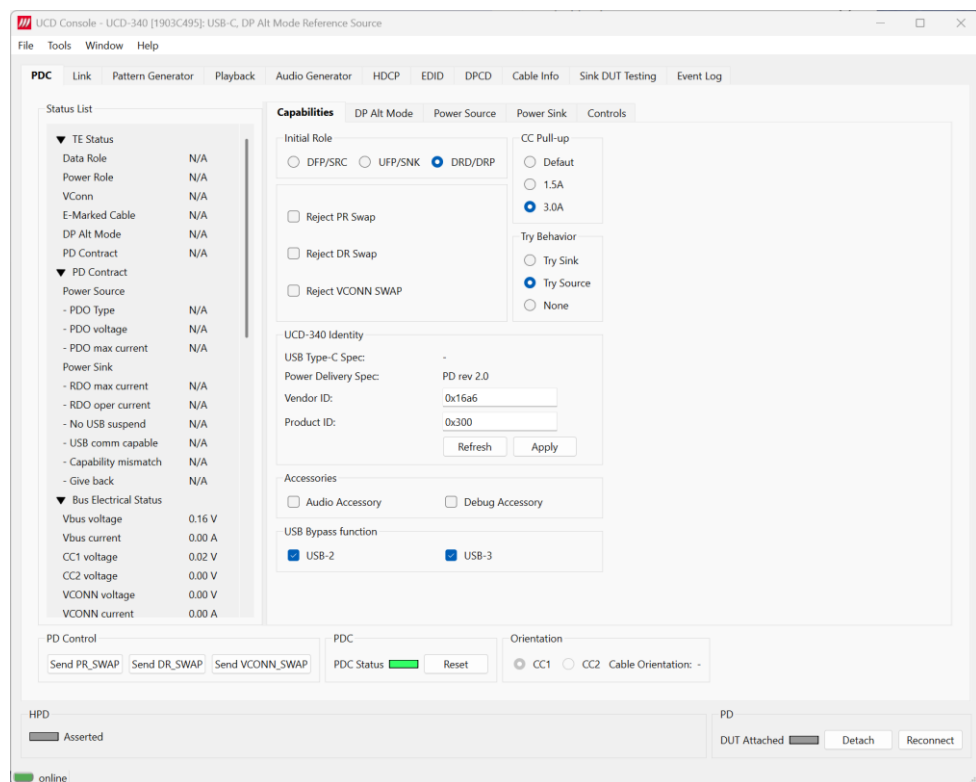

# 6. UCD TIMELINE VIEWER

UCD Timeline Viewer is an application for inspecting data captured in capture tab. It consists of four areas.

1. Frame View
2. Event View
3. Event Log
4. Details / Image

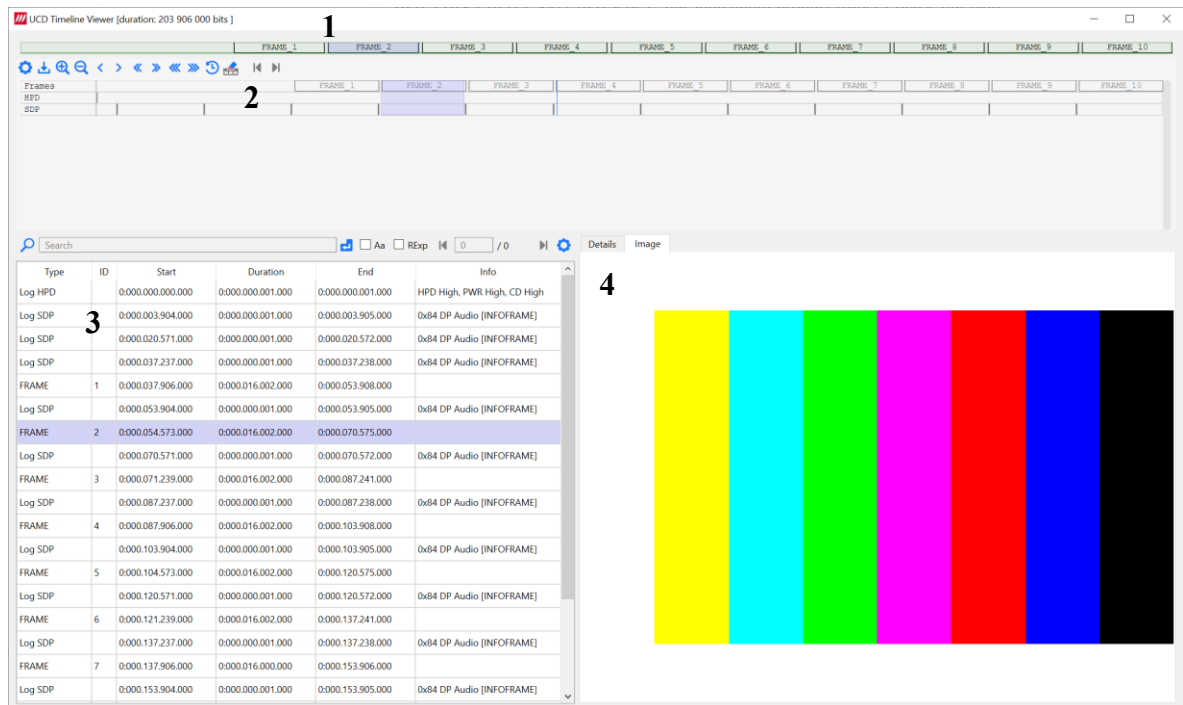

## Frame View

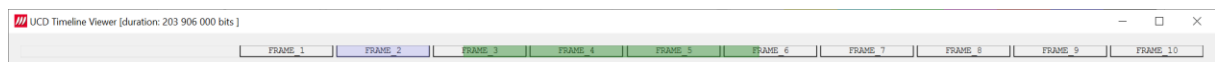





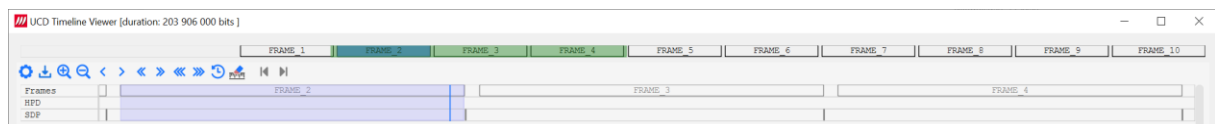

The uppermost panel shows the captured frames. The selected frame is highlighted in purple. You can select a frame by double-clicking it. The area highlighted in green indicates the area shown in the Events view. Please, note that you cannot zoom in or out in the frame view.

## Event View



The view below shows all frames and events selected in the capture tab. The are highlighted in green in frame view indicates the are shown in events view.

## Tools

Tool	Function
 Gear Icon	Hide / add events on the timeline
 Save Icon	Save, load, remove, import, export and remove presets
 Magnifying Glass Icons	Zoom in/out on the timeline
 Arrow Icons	Move on the timeline. More arrows moves the timeline more. You can also move by clicking and dragging in the timeline.
 Move to a time point	Move to a certain time point on the timeline by double clicking on the timeline. The selected event is highlighted in the event log. By right clicking on the timeline and right clicking again you can measure distance between two time points.
 Erase all rulers	Erase all measurements made.

## Zooming on the timeline

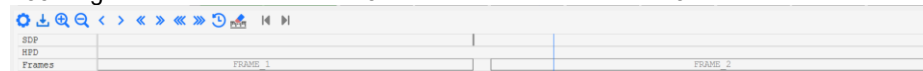

When the timeline is zoomed out, you can see events as grey lines. When you zoom in you can see the event block. You can zoom in either with the magnifying glass icons or by scrolling with your mouse.

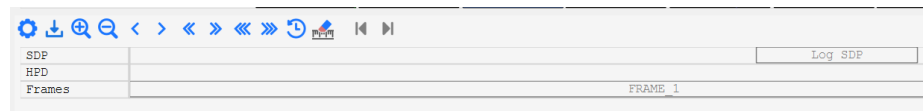

When you double click on event or frame, the corresponding event or frame is selected in the event log and highlighted in purple.

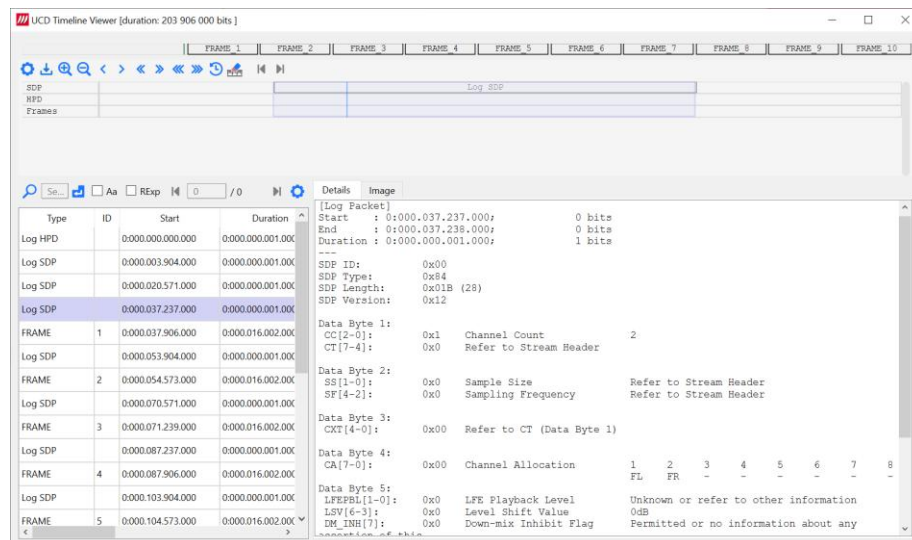

## Event Log

Type	ID	Start	Duration	End	Info
Log HPD		0:000.000.000.000	0:000.000.001.000	0:000.000.001.000	HPD High, PWR High, CD High
Log SDP		0:000.003.904.000	0:000.000.001.000	0:000.003.905.000	0x84 DP Audio [INFOFRAME]
Log SDP		0:000.020.571.000	0:000.000.001.000	0:000.020.572.000	0x84 DP Audio [INFOFRAME]
Log SDP		0:000.037.237.000	0:000.000.001.000	0:000.037.238.000	0x84 DP Audio [INFOFRAME]
FRAME	1	0:000.037.906.000	0:000.016.002.000	0:000.053.908.000	
Log SDP		0:000.053.904.000	0:000.000.001.000	0:000.053.905.000	0x84 DP Audio [INFOFRAME]
FRAME	2	0:000.054.573.000	0:000.016.002.000	0:000.070.575.000	
Log SDP		0:000.070.571.000	0:000.000.001.000	0:000.070.572.000	0x84 DP Audio [INFOFRAME]
FRAME	3	0:000.071.239.000	0:000.016.002.000	0:000.087.241.000	
Log SDP		0:000.087.237.000	0:000.000.001.000	0:000.087.238.000	0x84 DP Audio [INFOFRAME]
FRAME	4	0:000.087.906.000	0:000.016.002.000	0:000.103.908.000	
Log SDP		0:000.103.904.000	0:000.000.001.000	0:000.103.905.000	0x84 DP Audio [INFOFRAME]
FRAME	5	0:000.104.573.000	0:000.016.002.000	0:000.120.575.000	
Log SDP		0:000.120.571.000	0:000.000.001.000	0:000.120.572.000	0x84 DP Audio [INFOFRAME]
FRAME	6	0:000.121.239.000	0:000.016.002.000	0:000.137.241.000	
Log SDP		0:000.137.237.000	0:000.000.001.000	0:000.137.238.000	0x84 DP Audio [INFOFRAME]
FRAME	7	0:000.137.906.000	0:000.016.000.000	0:000.153.906.000	
Log SDP		0:000.153.904.000	0:000.000.001.000	0:000.153.905.000	0x84 DP Audio [INFOFRAME]

Event log shows all captured events and frames. The following info is presented in the table:

Type	Function
ID	Number of captured frame
Start	Start of the event
Duration	Duration of the event
End	End of the event
Info	Additional information about the event.

### Event Log Tools

Search	Search events from the event log. Search results are highlighted in purple.
Apply search filters	Apply filters.
<input type="checkbox"/> Aa <input type="checkbox"/> RExp Search filters	Aa filter: Make search case sensitive RExp: Use regular expressions in search
7 / 12 Search results	Shows search results. Move from one search result to another by clicking the arrows.
Configure	Selec which columns are shown in event log.

## Details / Image

Details
Image

```

[Log Packet]
Start   : 0:000.103.904.000;      0 bits
End     : 0:000.103.905.000;      0 bits
Duration: 0:000.000.001.000;      1 bits
---
SDP ID:      0x00
SDP Type:    0x84
SDP Length:  0x01B (28)
SDP Version: 0x12

Data Byte 1:
CC[2-0]:    0x1  Channel Count      2
CT[7-4]:    0x0  Refer to Stream Header

Data Byte 2:
SS[1-0]:    0x0  Sample Size        Refer to Stream Header
SF[4-2]:    0x0  Sampling Frequency  Refer to Stream Header

Data Byte 3:
CXT[4-0]:   0x00 Refer to CT (Data Byte 1)

Data Byte 4:
CA[7-0]:    0x00 Channel Allocation
              1   2   3   4   5   6   7   8
              FL  FR  -   -   -   -   -   -

Data Byte 5:
LFEPL[1-0]: 0x0  LFE Playback Level  Unknown or refer to other information
LSV[6-3]:   0x0  Level Shift Value    0dB
IM_INH[7]:  0x0  Down-mix Inhibit Flag Permitted or no information about any assertion of this

SDP_Header_CRC: Good
SDP_Body_CRC:   Good

Raw Data:
Head: 00 84 1B 48 (FB: 00 84 D7 D1)
Body: 01 00 00 00 00 00 00 00 00 00 00 00 00 00 00 00 (FB: 98 00 00 00)
      00 00 00 00 00 00 00 00 00 00 00 00 00 00 00 00 (FB: 00 00 00 00)
        
```

Details tab shows details of the selected event. When the selected event is a frame, the image tab shows the captured frame.

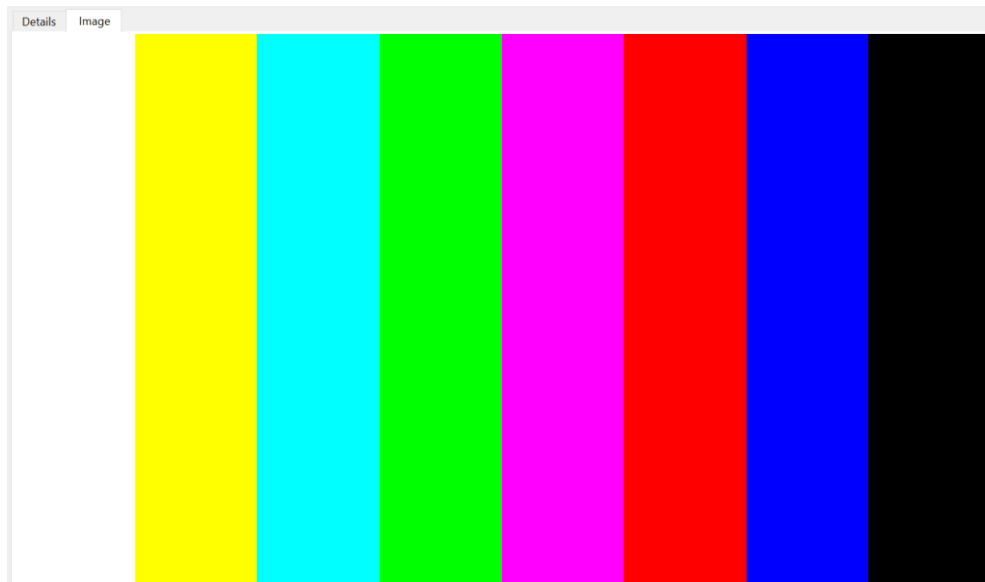

# 7. EVENT LOG

*Event Logger* (Event Log) collects time stamped information from the display interface. The type of data items logged is dependent on the display interface used and the role selected.

Event Log dialog is divided into two panels: the left panel lists all transactions, and the right panel shows the parsed transaction data for the line selected in the list on the left.

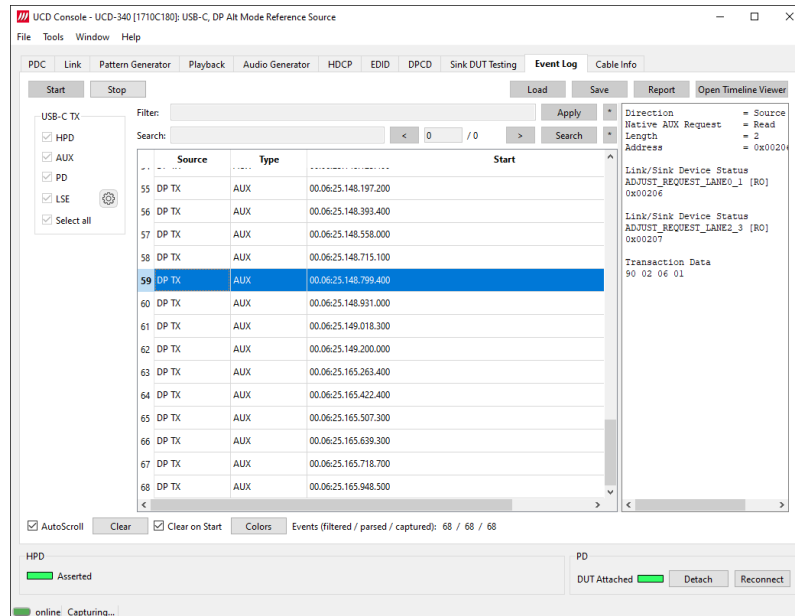

Role	Logged Events
DP Sink	HPD, SDP, AUX Transactions
DP Source	HPD, AUX Transactions
DP Alt Mode Sink	PD, LSE

<i>Start:</i>	Starts event logging and stop it by clicking <i>Stop</i> .
<i>Save:</i>	Save transactions as Event Log data.
<i>Load:</i>	Load saved Event Log data.
<i>Report:</i>	Store event logs as html reports to be shared and viewed with any web browser.
<i>Open Timeline Viewer</i>	Open captured data for viewing in timeline viewer.
<i>AutoScroll:</i>	When selected, transaction list is scrolled vertically, and the latest transaction is shown as the last item of the list. When not selected, the items shown before clicking Start will be shown.
<i>Events</i>	Number of events detected.
<i>Clear:</i>	Click to clear transaction list. When <i>Clear on Start</i> is selected, the list is cleared when clicking Start.

## Logged Events

### HPD

Status and status changes of Hot Plug Detect (HPD) signal.

### SDP

Secondary-data Packets received in DP Main-Link. Click the  button to open the *Event Filter Dialog*. The dialog enables filtering of SDP packets. In the dialog, the reference to Packet Type Value is indicated in square brackets “[ ]”.

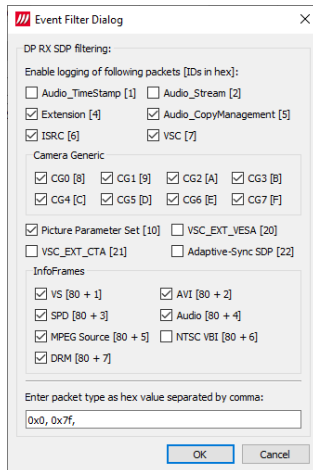

### AUX

DP AUX Channel transactions.

### PD

Log USB-C PD communication messages.

### LSE

Low Speed Electrical logger captures the Voltage and Current on the low-speed lanes of the

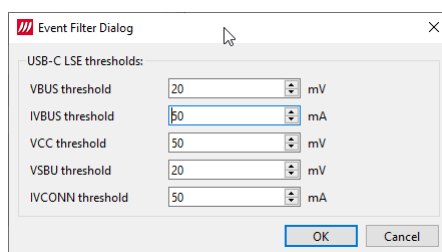

USB-C connector including CC, VBUS, VCONN, and SBU.

In Event Filter Dialog the user can set the noise threshold values. Only measurement exceeding the corresponding threshold will be logged.

## Event Transaction List

Transaction data in Transaction List is ordered in columns. Each column provides additional information about the data line, facilitating its viewing and interpretation.

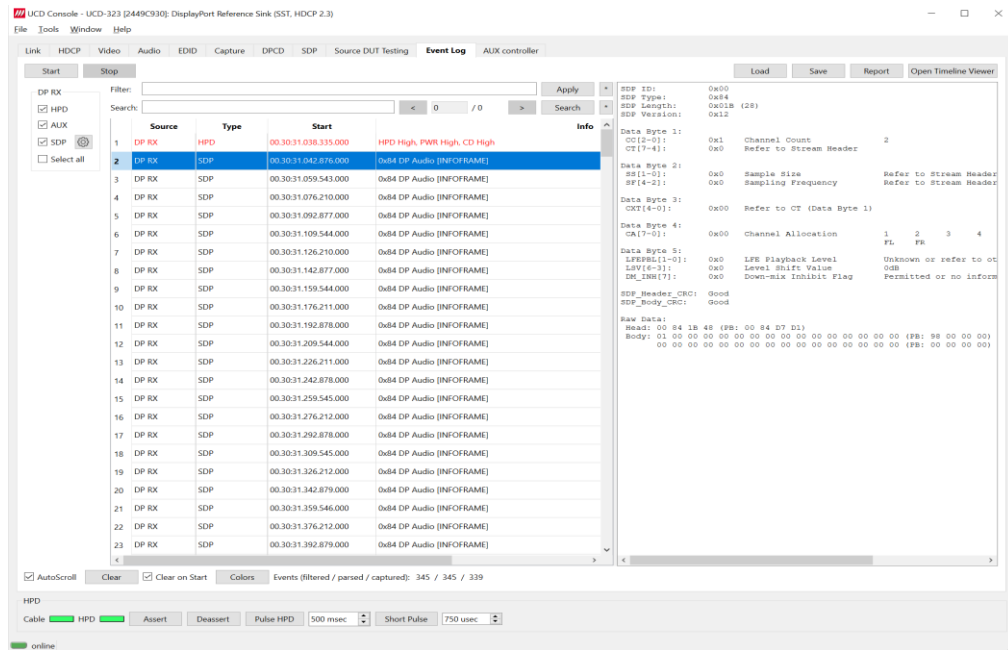

**Start:** Each line is identified by its timestamp, marking the instant when an event or error was detected, or when a data transaction got started. The timestamp can be displayed as a time delay from the start of the acquisition (absolute) or from the previous line (relative). The timestamp can be displayed in milliseconds or in minutes, seconds, and microseconds.

**Source and Type** The communication port: DP RX to DP TX

**Type** The logged item: HPD, SDP, AUX, MSA Change or VB-ID change

**Info** This column provides a short description of the message content

## Customizing Transaction List

User Can change what data is shown in the transaction list by adding and removing columns or limiting the transaction types in the list. User can also color highlight various types of transactions for better readability.

Right-click on the list to open the menu.

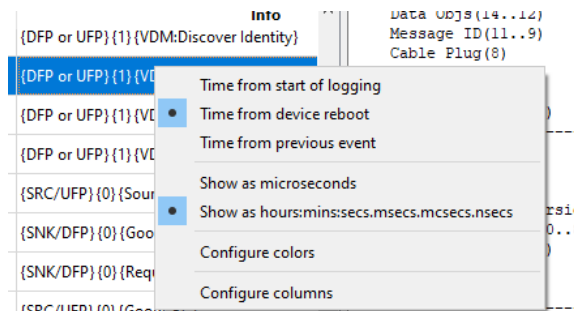

### Configure Start

The time indicated in column *Start* can be either:

- Time from start of logging
- Time from device reboot
- Time from previous event

The time can be expressed either:

- In microseconds (1/1 000 000 Second)
- Hours : minutes : seconds : milliseconds : nanoseconds

### Configure Colors

*Configure colors* dialog allows the user to highlight various types of transactions in the list by changing character color and background color of the transaction line.

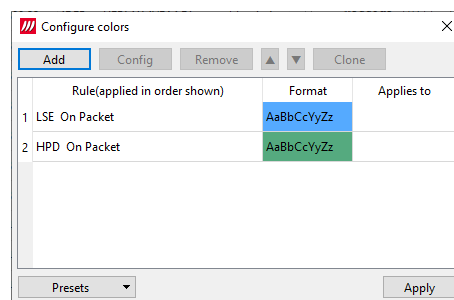

<i>Add:</i>	Add a new color highlight rule
<i>Config:</i>	Modify the selected rule
<i>Remove:</i>	Delete the selected rule
<i>Clone:</i>	Duplicate the selected rule
▲ ▼:	Change order where rules are applied. The rules are applied from the bottom to the top of the list.

## Adding Rules

The color highlight rules are set by transaction type. The content of *Add rules* dialog is dependent on the type of item selected.

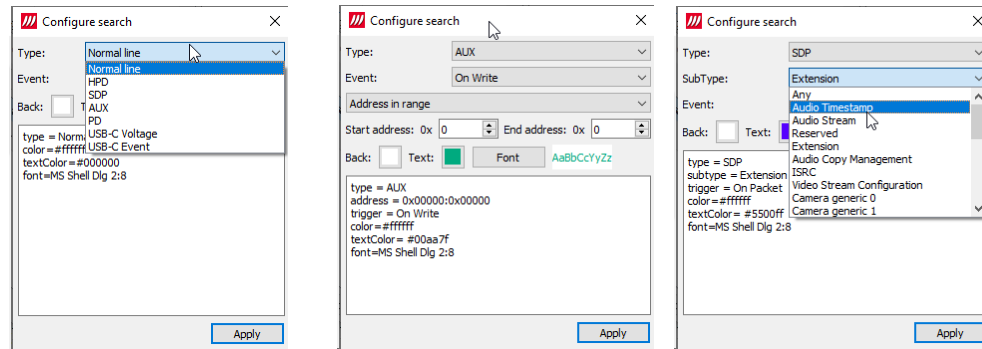

## Configure Columns

In the dialog there are two columns: *Available* and *Active*. An item from Available list can be included in Active columns by selecting it and clicking on the right arrow [>] in the middle of the two columns.

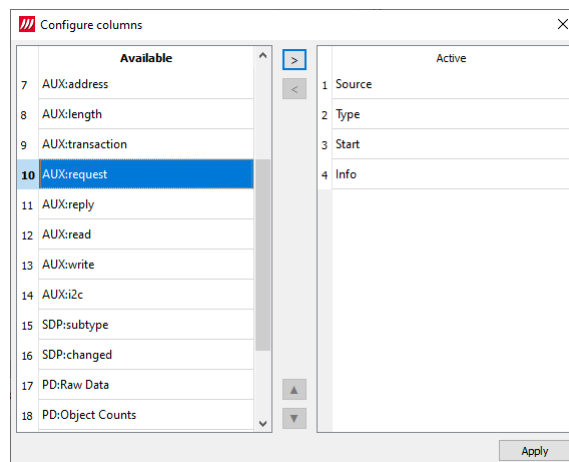

The order of Active items can be changed by selecting an item and moving its position in the list with up ▲ and down ▼ arrows.

## Type Filter

Type filter dialog lists the types of transactions found in the list and allows the user to select which transaction lines are currently shown.

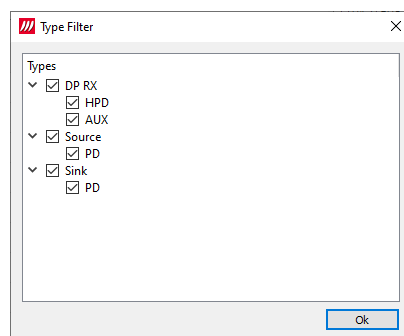

## Quick Filter

By entering a DPCD address in the Quick Filter field at the top of the transaction line, the user can limit the list to show only the reads or writes to this DPCD address.

## Parsed Transactions

### HPD

Status and status changes of Hot Plug Detect (HPD) signal.

```
Device ID           = 01 [DP RX]
Hot-Plug-Detect Level = HIGH
PWR Level          = HIGH (DP Tx is connected to Rx and has power applied to AUX pu
Cable Detect Level  = HIGH
```

### AUX (UCD-340)

DP AUX Channel transactions.

```
Direction           = Source to Sink
Native AUX Request  = Write
Length              = 4
Data                = 0A 0A 0A 0A
Address             = 0x00103

Link Configuration
TRAINING_LANE0_SET
0x00103 := 0x0A
  VOLTAGE_SWING_SET = level 2
  MAX_SWING_REACHED = level 0
  PRE_EMPHASIS_SET  = level 1
  MAX_PRE-EMPHASIS_REACHED = 0

  NOTE: Decoded as MAIN_LINK_CHANNEL_CODING_SET = 8b/10b

Link Configuration
TRAINING_LANE1_SET
0x00104 := 0x0A
  VOLTAGE_SWING_SET = level 2
  MAX_SWING_REACHED = level 0
  PRE_EMPHASIS_SET  = level 1
  MAX_PRE-EMPHASIS_REACHED = 0

  NOTE: Decoded as MAIN_LINK_CHANNEL_CODING_SET = 8b/10b

Link Configuration
TRAINING_LANE2_SET
0x00105 := 0x0A
  VOLTAGE_SWING_SET = level 2
  MAX_SWING_REACHED = level 0
  PRE_EMPHASIS_SET  = level 1
  MAX_PRE-EMPHASIS_REACHED = 0

  NOTE: Decoded as MAIN_LINK_CHANNEL_CODING_SET = 8b/10b

Link Configuration
TRAINING_LANE3_SET
0x00106 := 0x0A
  VOLTAGE_SWING_SET = level 2
  MAX_SWING_REACHED = level 0
  PRE_EMPHASIS_SET  = level 1
  MAX_PRE-EMPHASIS_REACHED = 0

  NOTE: Decoded as MAIN_LINK_CHANNEL_CODING_SET = 8b/10b
```

## SDP (UCD-340)

### DP Secondary-data Packets.

```
SDP ID:          0x00
SDP Type:        0x04
SDP Length:      0x01B (27)
SDP Version:     0x12 (18)

Data Byte 1:
CC[2-0]:        0x1  Channel Count           2
CT[7-4]:        0x0  Refer to Stream Header

Data Byte 2:
SS[1-0]:        0x0  Sample Size             Refer to Stream Header
SF[4-2]:        0x0  Sampling Frequency      Refer to Stream Header

Data Byte 3:
CXI[4-0]:       0x00  Refer to CT (Data Byte 1)

Data Byte 4:
CA[7-0]:        0x00  Channel Allocation      1   2   3   4   5   6
                                         FL  FR  -   -   -   -

Data Byte 5:
LFEPL[1-0]:     0x0  LFE Playback Level      Unknown or refer to other inform
LSV[6-3]:       0x0  Level Shift Value       0dB
DM_INH[7]:      0x0  Down-mix Inhibit Flag   Permitted or no information about

Raw Data:
Head: 00 84 1B 48 (PB: 00 84 D7 D1)
Body: 01 00 00 00 00 00 00 00 00 00 00 00 00 00 00 00 (PB: 98 00 00 00)
      00 00 00 00 00 00 00 00 00 00 00 00 00 00 00 00 (PB: 00 00 00 00)
```

## 8. EDID EDITOR

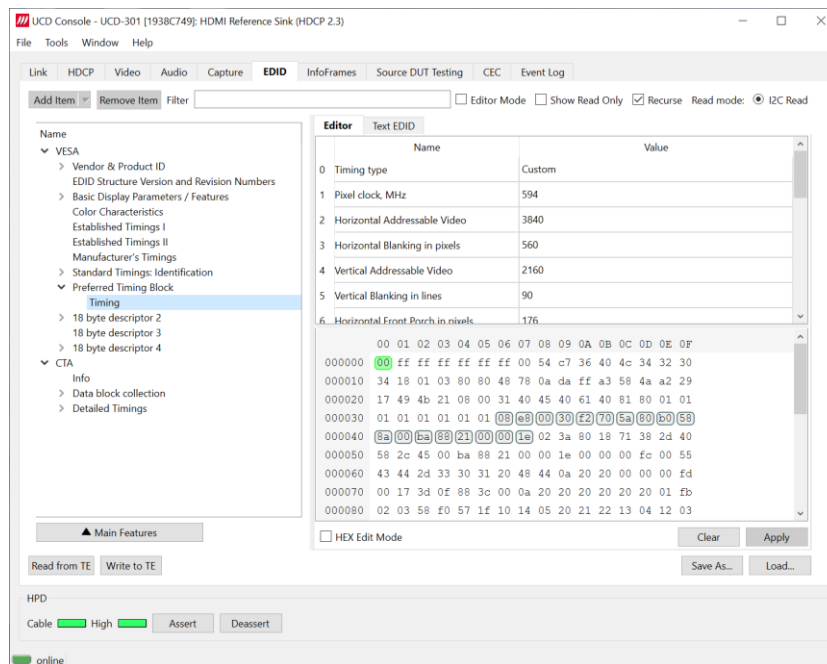

The *EDID/DisplayID Editor* main window is divided into three views. Command buttons are additionally located in the bottom. The top left *Navigation View* selection focuses and highlights the *Editor View* (top-right) and *Hex Editor View* (bottom-right). The *Editor View* values may be edited when the *Editor Mode* checkbox is checked. *Hex Editor View* presents blocks as hex values and can be edited when the *HEX Edit Mode* checkbox is checked.

### Controls

<i>Add Item</i>	Add a new EDID or DisplayID block. Available when in <i>Editor Mode</i> exclusively.
<i>Remove Item</i>	Delete the selected EDID or DisplayID block. Available when in <i>Editor Mode</i> exclusively.
<i>Filter</i>	Show only items having the filter string in their field name.
<i>Editor Mode</i>	Enable editor mode
<i>Read mode</i>	Select EDID data reading mode: I2C (using I2C protocol) or SBM (MST mode only): virtual channels read via SBM protocol.
<i>Show Read Only</i>	Automatically generated non-editable fields are additionally shown.
<i>Recurse</i>	All subitems of the selected item are presented in <i>Editor View</i> .

The buttons in the bottom of the dialog differ based on the role selected, i.e., is the subject the local EDID or EDID of a connected device.



**Main Features:**

The Main features panel gives an overview of items of common interest. For example, whether the sink is capable of HDR, or Dolby Vision. The small grey italic text shows corresponding location in EDID. If you click on the Value cell, the corresponding address in the HEX mode table is shown.

Features	CTA v3	CTA v3	CTA v3	
	Name		Value	
1	HDR Static <small>Data: block as selection</small>		Enabled	
2	HDR Dynamic <small>Data: block as selection</small>		Enabled	
3	HDR10+ <small>Data: block as selection</small>		Enabled	
4	Dolby Vision <small>Data: block as selection</small>		v2	
5	SBTM <small>Data: block as selection</small>		Enabled	
6	QMS <small>Vendor-Specific Data: Block -&gt;Block Data -&gt;HDMI Forum V</small>		Enabled	
7	VRR <small>Vendor-Specific Data: Block -&gt;Block Data -&gt;HDMI Forum V</small>		Enabled	
8	FRL <small>Vendor-Specific Data: Block -&gt;Block Data -&gt;HDMI Forum V</small>		Enabled	
9	DSC		Enabled	

<b>Read from TE (Analyzer):</b>	Read UCD-3XX local EDID.
<b>Write to TE (Analyzer):</b>	Program UCD-3XX local EDID. Please see the Note below.
<b>Read from TE (Generator):</b>	Read EDID of a connected sink device.
<b>Write to TE (Generator):</b>	Program EDID of a connected sink device.
<b>Editor Mode:</b>	Enable editing EDID content in parsed logical fields. When disabled, all the controls are in read-only mode. For example, for testing purposes it's possible to load invalid EDID and write it to TE without modifications. Once editor mode is enabled, EDID validator corrects errors such as invalid checksums. Modifications are possible in the upper panel with Name – Value pairs.
<b>HEX Edit Mode:</b>	Enable editing EDID content in HEX mode table. When enabled, modifications are possible in the lower panel with HEX values. Click the Apply button to validate the changes and copy them to the upper panel.
<b>Save As...:</b>	Save the current block collection to a disk file.
<b>Load ...:</b>	Load an EDID block collection file from disk.

## EDID Editor Features

A practically unlimited number of extension blocks may exist in a single collection. The number of blocks is limited by VESA Specifications and possibly by available system resources. Most EDID/DisplayID blocks contain a structure that is very similar to a tree structure. The Editor decodes each block into a tree view of the block. The tree view then contains all values within the data block. Contents can be browsed. The Editor has a support for automatic variables, such as the block checksum. When a value in a block is modified, the checksum will be updated. Automatic variables are read only. A log print will be made when an automatic variable is updated by the editor.

## Editing Tips

Editing is straightforward:

- Select property fields to edit.
- Red values in *HEX View* show that values have been modified.

Press *Enter* to apply edit values and combo box selections.

In CTA-861 blocks, you can add and remove 18-byte descriptors and CEA data blocks by setting the values “18-byte Descriptors in this block” and “CEA Data block count”.

Enter hex values with prefixes “0x” or “\$”. No prefix represents a decimal value.

Values may be entered as hexadecimal or decimal regardless of presentation.

Floating point values must have a period “.” decimal separator.

Click *Set* after changing a bit-value presented as a single checkbox if you want the new value applied.

---

**Note:** EDID Editor does not have an *Undo* function. Therefore, it is highly recommended that you back up un-edited EDID contents to a file before editing it.

---

## 9. PACKET EDITOR

### Introduction

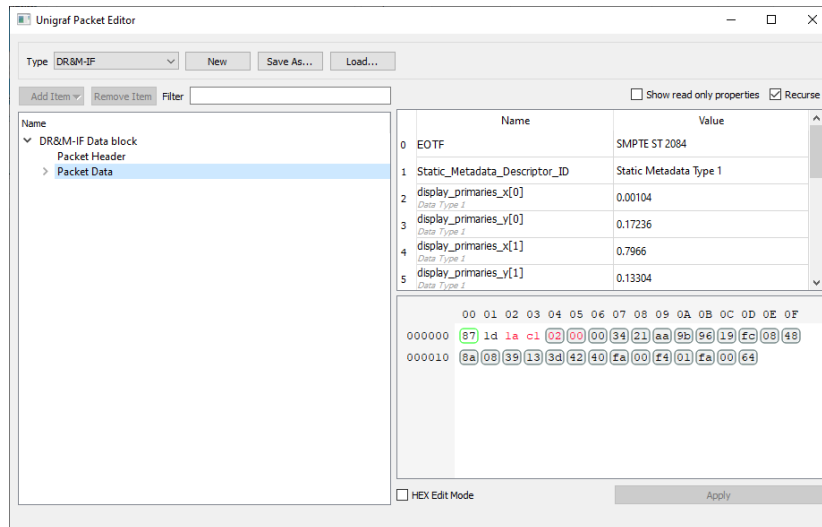

Packet Editor enables creation and editing metadata packets to be included Scenarios played with Playback function. Open packet editor from UCD Console's menu **Tools > Packet Editor**.

The types of packets are:

- Audio InfoFrame (Audio)
- AVI InfoFrame (AVI)
- Custom InfoFrame (Custom) (HDMI)
- Custom Packet (custom) (DP)
- DR&M InfoFrame (DR&M) (HDMI)
- DR&M Packet (DR&M) (DP)
- EMP-VRR (EMP-VRR)
- GCP InfoFrame (GCP)
- SBTM InfoFrame (SBTM) (HDMI)
- SPD InfoFrame (SPD)
- Vendor-Specific InfoFrame (VS) (HDMI)\*
- Vendor-Specific SDP (VS) (DP)\*

\*) Please select from available VS packet types in field "4: Type" in the packet editor.

# 10. PATTERN EDITOR

## Introduction

Pattern Editor is a tool for editing and debugging Unigraf Custom VTP Pattern scripts. Open packet editor from UCD Console's menu **Tools > Pattern Editor**.

Please refer to APPENDIX F: VTP PATTERN LANGUAGE later in this document for description of the VTP Pattern Language syntax.

Pattern Editor consists of three tabs:

### Image Tab

Monitoring the rendering of the VTP pattern script.

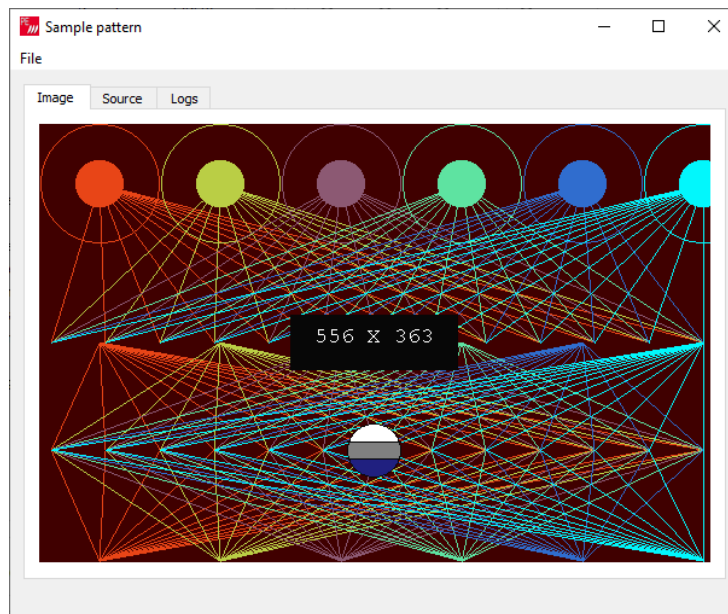

## Source Tab

Tool for editing VTP Pattern Language script. Click Apply to render the code in the resolution of the preview image in *Image* tab.

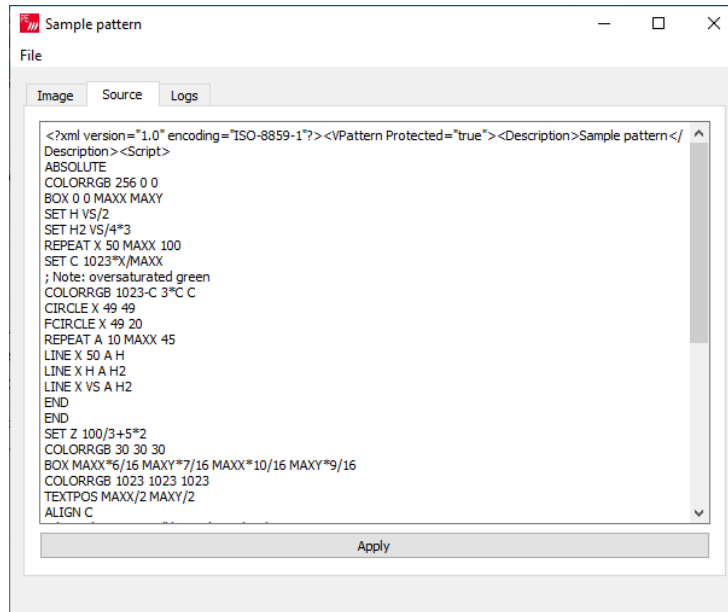

## Logs Tab

Log of the pattern code parsing indicating the values assigned to logical variables and the actual parameter values used for render instructions.

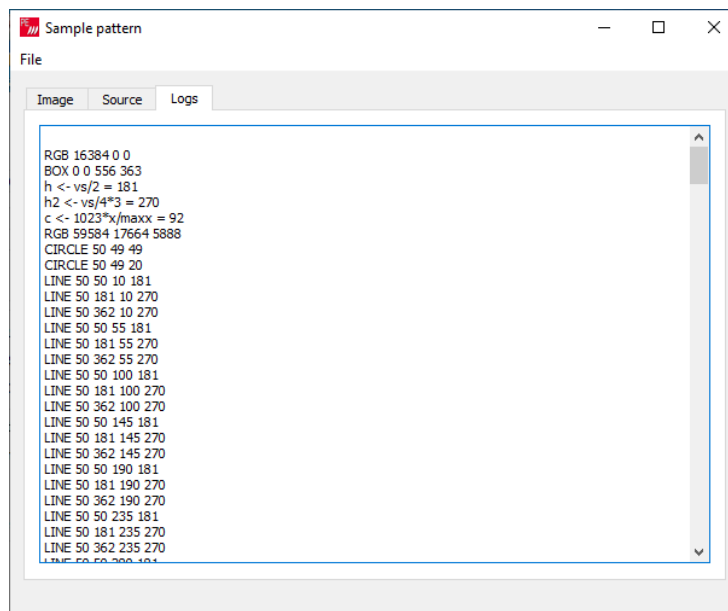

## Saving and Recalling the Script

In File pull-down menu the user can save his work.

*Open:* Open a VTP language script from PC

*Save Script:* Save the script currently in Source tab to PC

*Save Image:* Save a rendered pattern in PNG, BMP, JPG or PPM format

*Select Save Resolution:* Select from six common resolutions the size in which the pattern script will be rendered when saved.

# 11. IMAGE CONVERTER

Image Converter is a tool for converting images from one color format to another. This kind of conversion is typically needed when creating YCbCr test images from RGB bitmaps. Open the image converter from UCD Console's menu **Tools > Image Converter**.

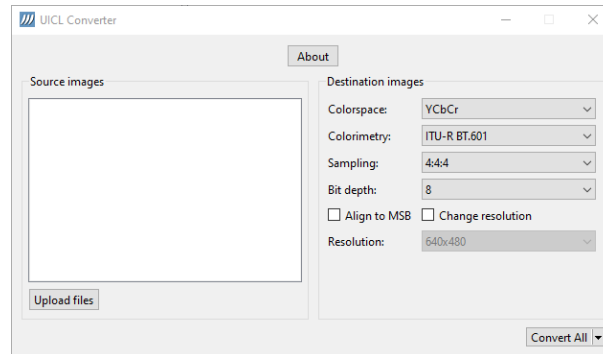

Click **Upload files** to load the Source image.

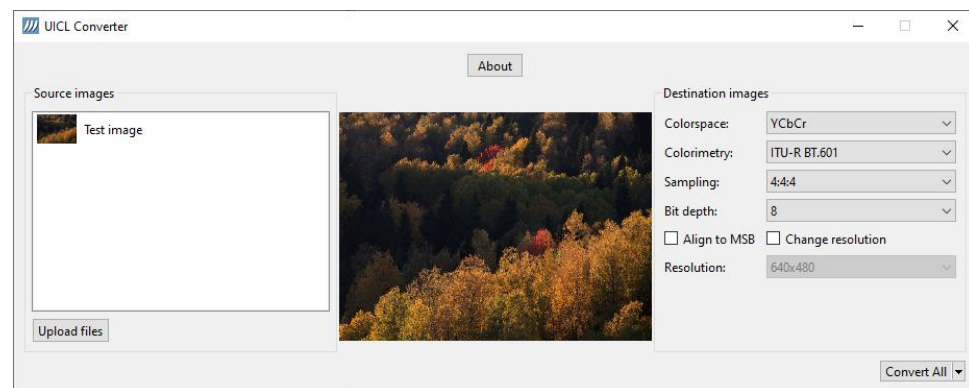

<i>Colorspace</i>	YCbCr, RGB
<i>Colorimetry</i>	ITU-R BT.601, ITU-R BT.709, ITU-R BT2020
<i>Sampling</i>	4:4:4, 4:2:2, 4:2:0
<i>Bit depth</i>	8, 10, 12, 16
<i>Align to MSB</i>	Store binary data aligned to the Most Significant Bit (MSB). When this is left unchecked the binary data is aligned to the Least Significant Bit (LSB).
<i>Change resolution</i>	Select a resolution for the destination image from the pre-defined list
<i>Convert All</i>	Convert all uploaded images to destination format and save them in the same folder as the source images.
<i>Convert All and save to the custom folder</i>	Convert all uploaded images to destination format and save to the selected folder.

File name for the destination image is of form:

**Test image[1920x1080\_yuv444\_8bpc\_BT601\_Packed\_YCbCr\_LSB]**

# APPENDIX A: PRODUCT SPECIFICATION

## UCD-340

Test Connections	USB Type-C (Dual Role Port) USB Type-A (test signal Device) pass-thru USB Type-B (Host) pass-thru External Power Source / Sink connector
DP Alt Mode	Resolution up to 4096 × 2160p60 Up to HBR2 rate in up to 4 lanes Color depth up to 48 bits Support HDCP 1.3 and 2.3
USB Over USB-C	USB 3.1 Gen1 (5 Gbps) and USB 2.0 pass-thru
USB Power Delivery	Sink and source 5 V up to 3.0 A, up to 20 V / 5 A with external power test unit (Optional)
Electrical Test	Verify voltage current flow in USB Type-C interface signals (VBUS, GROUND, CC1/2, SBU1/2). (Optional)
Computer interface	USB 3.0
Software	Windows 11, 10 and 8 compatible software driver. UCD Console application for Windows Compatible with Unigraf TSI
Power supply	AC/DC Power supply (100 to 240 Vac 50/60 Hz input, +12 Vdc output)
Environmental	Operating temperature: 15 to 35 deg C Storage temperature: 0 to 50 deg C Humidity 30% to 70% RH, non-condensing
Mechanical Size	281 × 128 × 62 mm
Weight	0.9 kg w/o power supply

All specifications are subject to change without notice.

APPENDIX B: PRODUCT FEATURES

UCD-340

Input /Output Role	UCD-340 Default	Console Pro	HDCP 2.3 support (Console Pro)	HDCP 2.3 CTS Sink / Source DUT	TSI Basic	TSI Advanced	HDCP 2.3 support
<b>DP Reference Sink</b>							
Video status, preview and saving	•				▲		
Buffered capture		•					
Audio monitoring, graphical preview and saving	•				▲		
Link status	•				▲		
Link control		•				▲	
HPD status and control	•				▲		
DPCD editor		•					
Monitor InfoFrame Status (SDP)		•				▲	
EDID read and write		•				▲	
EDID / DisplayID Editor		•					
HDCP 1.3 status and control		•					
HDCP 2.3 status and control			•				▲
Event Log, AUX Analyzer		•					
Source DUT Testing (Link and CRC test)		•				▲	
Electrical Test	•				▲		
HDCP 2.3 CTS for testing DP Source DUT				•			
<b>DP Reference Source</b>							
Video pattern generator (fixed patterns and timings)	•				▲		
Custom video patterns and timings		•				▲	
Audio generator	•						
Playback		•				▲	
Link status	•				▲		
Link control		•				▲	
HPD status	•					▲	
EDID read and write	•					▲	
EDID / DisplayID Editor		•					
DPCD editor		•					
HDCP 1.3 status and control		•				▲	
HDCP 2.3 status and control			•				▲
Event Log, AUX Analyzer		•					
Sink DUT Testing		•					
HDCP 2.3 CTS for testing DP Sink DUT				•			

## UCD-340 (cont.)

Input /Output Role	UCD-340 Default	Pro License	TSI Basic	TSI Advanced
<b>USB-C Modes Common</b>				
USB-C Data Role status & control	•		▲	
USB-C Power Role status & control	•		▲	
USB-C Vbus / CC / Vconn voltage / current monitoring	•		▲	
Power Delivery protocol monitoring		•		▲
Cable Info (E-marker details)		•		▲
Electrical cable flip test	•		▲	
Event Logger		•		
Support for USB-C Power for 5V/3A	•		▲	
Support for USB-C External Power Unit up to 20V/5A		•		▲
USBC Electrical Test option	•		▲	
<b>DP Alt Mode Common</b>				
USB-C DP ALT Mode status	•		▲	
USB-C DP ALT Mode control	•		▲	

### UCD-340 Product SW Options

Product	P/N
UCD Console Pro for Type-C DP Sink key	MT6640
UCD Console Pro for Type-C DP Source key	MT6641
HDCP 2.3 support	MT6504
DP HDCP 2.3 CTS for testing Source DUT	MT6634
DP HDCP 2.3 CTS for testing Sink DUT	MT6636
TSI SDK Advanced Test Set	MT6501

## APPENDIX C: PREDEFINED TIMINGS

Description	TSI*	HA	VA	HT	VT	HST	VST	HSYN	VSYN	FR	Pixel Clock (MHz)
CVT 640x480 @60Hz	0	640	480	800	525	144	35	96	2	60	25.20
CTA 640x480 @60Hz (VIC 1)	1	640	480	800	525	144	35	96	2	60	25.17
CTA 720x480 @60Hz (VIC 2)	2	720	480	858	525	122	36	62	6	60	27.00
CTA 720x480 @60Hz (VIC 3)	3	720	480	858	525	122	36	62	6	60	27.00
CTA 720x576 @50Hz (VIC 17)	4	720	576	864	625	132	44	64	5	50	27.00
CTA 720x576 @50Hz (VIC 18)	5	720	576	864	625	132	44	64	5	50	27.00
CTA 720x576 @100Hz (VIC 42)	6	720	576	864	625	132	44	64	5	100	54.00
CTA 720x576 @100Hz (VIC 43)	7	720	576	864	625	132	44	64	5	100	54.00
CTA 720x480 @120Hz (VIC 49)	8	720	480	858	525	122	36	62	6	120	54.00
CTA 720x480 @120Hz (VIC 48)	9	720	480	858	525	122	36	62	6	120	54.05
CTA 720x576 @200Hz (VIC 52)	10	720	576	864	625	132	44	64	5	200	108.00
CTA 720x576 @200Hz (VIC 53)	11	720	576	864	625	132	44	64	5	200	108.00
CTA 720x480 @240Hz (VIC 56)	12	720	480	858	525	122	36	62	6	240	108.00
CTA 720x480 @240Hz (VIC 57)	13	720	480	858	525	122	36	62	6	240	108.00
CVT 768x480 @85Hz	14	768	480	992	507	184	24	72	6	85	42.50
OVT 768x480 @85Hz	15	768	480	928	741	64	242	32	8	85	58.45
DMT 800x600 @60Hz (DMT 0x09)	16	800	600	1056	628	216	27	128	4	60	40.00
DMT 848x480 @60Hz (DMT 0x0E)	17	848	480	1088	517	224	31	112	8	60	33.75
CVT 1024x640 @60Hz	18	1024	640	1312	665	248	22	104	6	60	52.25
DMT 1024x768 @60Hz (DMT 0x10)	19	1024	768	1344	806	296	35	136	6	60	65.00
OVT 1024x640 @60Hz	20	1024	640	1240	660	64	16	32	8	60	49.10
CVT 1152x720 @75Hz	21	1152	720	1520	755	304	32	120	6	75	85.75
OVT 1152x720 @75Hz	22	1152	720	1280	1224	64	496	32	8	75	117.50
CTA 1280x720 @50Hz (VIC 19)	23	1280	720	1980	750	260	25	40	5	50	74.25
CTA 1280x720 @100Hz (VIC 41)	24	1280	720	1980	750	260	25	40	5	100	148.50
CTA 1280x720 @24Hz (VIC 60)	25	1280	720	3300	750	260	25	40	5	24	59.40
CTA 1280x720 @25Hz (VIC 61)	26	1280	720	3960	750	260	25	40	5	25	74.25
CTA 1280x720 @30Hz (VIC 62)	27	1280	720	3300	750	260	25	40	5	30	74.25
CTA 1280x720 @24Hz (VIC 65)	28	1280	720	3300	750	260	25	40	5	24	59.40
CTA 1280x720 @25Hz (VIC 66)	29	1280	720	3960	750	260	25	40	5	25	74.25
CTA 1280x720 @30Hz (VIC 67)	30	1280	720	3300	750	260	25	40	5	30	74.25
CTA 1280x720 @50Hz (VIC 68)	31	1280	720	1980	750	260	25	40	5	50	74.25
CTA 1280x720 @60Hz (VIC 69)	32	1280	720	1650	750	260	25	40	5	60	74.25
CTA 1280x720 @100Hz (VIC 70)	33	1280	720	1980	750	260	25	40	5	100	148.50
CTA 1280x720 @120Hz (VIC 71)	34	1280	720	1650	750	260	25	40	5	120	148.50
CTA 1280x720 @48Hz (VIC 108)	35	1280	720	2500	750	260	25	40	5	48	90.00
CTA 1280x720 @48Hz (VIC 109)	36	1280	720	2500	750	260	25	40	5	48	90.00
CTA 1280x720 @60Hz (VIC 4)	37	1280	720	1650	750	260	25	40	5	60	74.25
CTA 1280x720 @120Hz (VIC 47)	38	1280	720	1650	750	260	25	40	5	120	148.50
OVT 1280x720 @24Hz	39	1280	720	1600	925	64	194	32	8	24	35.52
OVT 1280x720 @120Hz	40	1280	720	1408	775	64	38	32	8	120	130.94

CVT 1280x768 @60Hz	41	1280	768	1440	790	112	19	32	7	60	68.26
DMT 1280x768 @60Hz (DMT 0x17)	42	1280	768	1664	798	320	27	128	7	60	79.67
OVT 1280x768 @60Hz	43	1280	768	1472	800	64	20	32	8	60	70.66
DMT 1280x800 @60Hz (DMT 0x1B)	44	1280	800	1440	823	112	20	32	6	60	71.11
DMT 1280x800 @60Hz (DMT 0x1C)	45	1280	800	1680	831	328	28	128	6	60	83.76
OVT 1280x960 @60Hz	46	1280	960	1440	1000	64	24	32	8	60	86.40
DMT 1280x960 @60Hz (DMT 0x20)	47	1280	960	1800	1000	424	39	112	3	60	108.00
CVT 1280x960 @60Hz	48	1280	960	1696	996	336	33	128	4	60	101.25
DMT 1280x1024 @60Hz (DMT 0x23)	49	1280	1024	1688	1066	360	41	112	3	60	107.96
DMT 1360x768 @60Hz (DMT 0x27)	50	1360	768	1792	795	368	24	112	6	60	85.48
DMT 1400x1050 @60Hz (DMT 0x29)	51	1400	1050	1560	1080	112	27	32	4	60	101.09
DMT 1400x1050 @60Hz (DMT 0x2A)	52	1400	1050	1864	1089	376	36	144	4	60	121.79
CTA 1440x480 @60Hz (VIC 6)	53	1440	480	1716	525	238	18	124	3	60	54.00
CTA 1440x480 @60Hz (VIC 7)	54	1440	480	1716	525	238	18	124	3	60	54.00
OVT 1440x240 @60Hz	55	1440	240	1920	260	64	14	32	8	60	29.95
CTA 1440x240 @60Hz (VIC 8)	56	1440	240	1716	263	238	18	124	3	60	27.00
CTA 1440x240 @60Hz (VIC 9)	57	1440	240	1716	262	238	18	124	3	60	27.00
CVT 1440x240 @60Hz	58	1440	240	1716	262	238	18	124	3	60	27.00
OVT 1440x480 @60Hz	59	1440	480	1696	500	64	12	32	8	60	50.88
CTA 1440x480 @60Hz (VIC 14)	60	1440	480	1716	525	244	36	124	6	60	54.00
CTA 1440x480 @60Hz (VIC 15)	61	1440	480	1716	525	244	36	124	6	60	54.00
CTA 1440x576 @50Hz (VIC 21)	62	1440	576	1728	625	264	22	126	3	50	54.00
CTA 1440x576 @50Hz (VIC 22)	63	1440	576	1728	625	264	22	126	3	50	54.00
CTA 1440x288 @50Hz (VIC 23)	64	1440	288	1728	314	264	22	126	3	50	27.00
CTA 1440x288 @50Hz (VIC 24)	65	1440	288	1728	314	264	22	126	3	50	27.00
CTA 1440x576 @50Hz (VIC 29)	66	1440	576	1728	625	264	44	128	5	50	54.00
CTA 1440x576 @50Hz (VIC 30)	67	1440	576	1728	625	264	44	128	5	50	54.00
CTA 1440x576 @100Hz (VIC 44)	68	1440	576	1728	625	264	22	126	3	100	108.00
CTA 1440x576 @100Hz (VIC 45)	69	1440	576	1728	625	264	22	126	3	100	108.00
CTA 1440x480 @120Hz (VIC 50)	70	1440	480	1716	525	238	18	124	3	120	108.00
CTA 1440x480 @120Hz (VIC 51)	71	1440	480	1716	525	238	18	124	3	120	108.00
CTA 1440x576 @200Hz (VIC 54)	72	1440	576	1728	625	264	22	126	3	200	216.00
CTA 1440x576 @200Hz (VIC 55)	73	1440	576	1728	625	264	22	126	3	200	216.00
CTA 1440x480 @240Hz (VIC 58)	74	1440	480	1716	525	238	18	124	3	240	216.00
CTA 1440x480 @240Hz (VIC 59)	75	1440	480	1716	525	238	18	124	3	240	216.00
OVT 1440x900 @60Hz	76	1440	900	1600	940	64	23	32	8	60	90.24
DMT 1440x900 @60Hz (DMT 0x2F)	77	1440	900	1904	934	384	31	152	6	60	106.50
OVT 1536x960 @85Hz	78	1536	960	1640	1440	64	469	32	8	85	200.74
CVT 1536x960 @85Hz	79	1536	960	2080	1011	432	48	160	6	85	178.50
CVT 1600x1200 @60Hz	80	1600	1200	1760	1235	112	32	32	4	60	130.42
DMT 1600x1200 @60Hz (DMT 0x33)	81	1600	1200	2160	1250	496	49	192	3	60	162.00
CTA 1680x720 @24Hz (VIC 79)	82	1680	720	3300	750	260	25	40	5	24	59.40
CTA 1680x720 @25Hz (VIC 80)	83	1680	720	3168	750	260	25	40	5	25	59.40
CTA 1680x720 @30Hz (VIC 81)	84	1680	720	2640	750	260	25	40	5	30	59.40

CTA 1680x720 @50Hz (VIC 82)	85	1680	720	2200	750	260	25	40	5	50	82.50
CTA 1680x720 @100Hz (VIC 84)	86	1680	720	2000	825	260	100	40	5	100	165.00
CTA 1680x720 @48Hz (VIC 110)	87	1680	720	2750	750	260	25	40	5	48	99.00
CTA 1680x720 @60Hz (VIC 83)	88	1680	720	2200	750	260	25	40	5	60	99.00
CTA 1680x720 @120Hz (VIC 85)	89	1680	720	2000	825	260	100	40	5	120	198.00
DMT 1680x1050 @60Hz (DMT 0x39)	90	1680	1050	1840	1080	112	27	32	6	60	119.23
DMT 1680x1050 @60Hz (DMT 0x3A)	91	1680	1050	2240	1089	456	36	176	6	60	146.36
DMT 1792x1344 @60Hz (DMT 0x3E)	92	1792	1344	2448	1394	528	49	200	3	60	204.75
DMT 1856x1392 @60Hz (DMT 0x41)	93	1856	1392	2528	1439	576	46	224	3	60	218.27
CTA 1920x1080 @60Hz (VIC 5)	94	1920	1080	2200	1125	192	20	44	5	60	148.50
CTA 1920x1080 @50Hz (VIC 20)	95	1920	1080	2640	1125	192	20	44	5	50	148.50
CTA 1920x1080 @50Hz (VIC 31)	96	1920	1080	2640	1125	192	41	44	5	50	148.50
CTA 1920x1080 @24Hz (VIC 32)	97	1920	1080	2750	1125	192	41	44	5	24	74.25
CTA 1920x1080 @25Hz (VIC 33)	98	1920	1080	2640	1125	192	41	44	5	25	74.25
CTA 1920x1080 @50Hz (VIC 39)	99	1920	1080	2304	1250	352	62	168	5	50	144.00
CTA 1920x1080 @100Hz (VIC 40)	100	1920	1080	2640	1125	192	20	44	5	100	297.00
CTA 1920x1080 @120Hz (VIC 46)	101	1920	1080	2200	1125	192	20	44	5	120	297.00
OVT 1920x1080 @30Hz	102	1920	1080	2144	1100	64	14	32	8	30	70.75
OVT 1920x1080 @60Hz	103	1920	1080	2080	1120	64	27	32	8	60	139.78
OVT 1920x1080 @85Hz	104	1920	1080	2016	1623	64	529	32	8	85	278.12
OVT 1920x1080 @100Hz	105	1920	1080	2016	1380	64	286	32	8	100	278.21
OVT 1920x1080 @120Hz	106	1920	1080	2016	1150	64	56	32	8	120	278.21
OVT 1920x1080 @144Hz	107	1920	1080	2040	1175	64	68	32	8	144	345.17
OVT 1920x1080 @240Hz	108	1920	1080	2000	1215	64	117	32	8	240	583.20
CTA 1920x1080 @100Hz (VIC 64)	109	1920	1080	2640	1125	192	41	44	5	100	297.00
CTA 1920x1080 @24Hz (VIC 72)	110	1920	1080	2750	1125	192	41	44	5	24	74.25
CTA 1920x1080 @25Hz (VIC 73)	111	1920	1080	2640	1125	192	41	44	5	25	74.25
CTA 1920x1080 @30Hz (VIC 74)	112	1920	1080	2200	1125	192	41	44	5	30	74.25
CTA 1920x1080 @50Hz (VIC 75)	113	1920	1080	2640	1125	192	41	44	5	50	148.50
CTA 1920x1080 @60Hz (VIC 76)	114	1920	1080	2200	1125	192	41	44	5	60	148.50
CTA 1920x1080 @100Hz (VIC 77)	115	1920	1080	2640	1125	192	41	44	5	100	297.00
CTA 1920x1080 @120Hz (VIC 78)	116	1920	1080	2200	1125	192	41	44	5	120	297.00
CVT 1920x1080 @30Hz	117	1920	1080	2080	1096	112	13	32	5	30	68.39
CVT 1920x1080 @30Hz	118	1920	1080	2000	1096	72	14	32	8	30	65.76
CVT 1920x1080 @144Hz	119	1920	1080	2080	1157	112	74	32	5	144	346.66
CVT 1920x1080 @144Hz	120	1920	1080	2000	1157	72	14	32	8	144	333.33
CVT 1920x1080 @144Hz	121	1920	1080	2080	1157	152	14	32	8	144	346.66
CVT 1920x1080 @200Hz	122	1920	1080	2080	1190	152	14	32	8	200	495.21
CVT 1920x1080 @240Hz	123	1920	1080	2080	1215	112	132	32	5	240	606.27
CVT 1920x1080 @240Hz	124	1920	1080	2000	1215	72	14	32	8	240	582.95
CVT 1920x1080 @240Hz	125	1920	1080	2080	1215	152	14	32	8	240	606.27
CTA 1920x1080 @30Hz (VIC 34)	126	1920	1080	2200	1125	192	41	44	5	30	74.25
CVT 1920x1080 @60Hz	127	1920	1080	2080	1111	112	28	32	5	60	138.65
CVT 1920x1080 @60Hz	128	1920	1080	2000	1111	72	14	32	8	60	133.32

DMT 1920x1080 @60Hz (DMT 0x52)	129	1920	1080	2200	1125	192	41	44	5	60	148.50
CTA 1920x1080 @60Hz (VIC 16)	130	1920	1080	2200	1125	192	41	44	5	60	148.50
CVT 1920x1080 @120Hz	131	1920	1080	2080	1144	112	61	32	5	120	285.54
CVT 1920x1080 @120Hz	132	1920	1080	2000	1144	72	14	32	8	120	274.56
CTA 1920x1080 @120Hz (VIC 63)	133	1920	1080	2200	1125	192	41	44	5	120	297.00
CTA 1920x1080 @48Hz (VIC 111)	134	1920	1080	2750	1125	192	41	44	5	48	148.50
CTA 1920x1080 @48Hz (VIC 112)	135	1920	1080	2750	1125	192	41	44	5	48	148.50
CVT 1920x1080 @85Hz	136	1920	1080	2624	1137	560	54	208	5	85	253.25
DMT 1920x1200 @60Hz (DMT 0x45)	137	1920	1200	2592	1245	536	42	200	6	60	193.62
OVT 1920x1440 @60Hz	138	1920	1440	2048	1500	64	36	32	8	60	184.32
DMT 1920x1440 @60Hz (DMT 0x49)	139	1920	1440	2600	1500	552	59	208	3	60	234.00
CVT 1920x1440 @60Hz	140	1920	1440	2080	1481	112	38	32	4	60	184.75
CVT 2048x1280 @60Hz	141	2048	1280	2208	1317	112	34	32	6	60	174.25
OVT 2048x1280 @60Hz	142	2048	1280	2200	1320	64	32	32	8	60	174.24
OVT 2048x1536 @60Hz	143	2048	1536	2200	1580	64	38	32	8	60	208.56
CVT 2048x1536 @60Hz	144	2048	1536	2208	1580	112	41	32	4	60	209.32
CVT 2128x1200 @60Hz	145	2128	1200	2864	1245	592	42	224	10	60	213.75
OVT 2128x1200 @60Hz	146	2128	1200	2280	1240	64	30	32	8	60	169.63
OVT 2456x1536 @50Hz	147	2456	1536	2600	1896	64	354	32	8	50	246.48
OVT 2456x1536 @75Hz	148	2456	1536	2560	2608	64	1057	32	8	75	500.74
CVT 2456x1536 @50Hz	149	2456	1536	3320	1583	696	44	264	10	50	262.78
CVT 2456x1536 @75Hz	150	2456	1536	3384	1606	728	67	264	10	75	407.25
CTA 2560x1080 @24Hz (VIC 86)	151	2560	1080	3750	1100	192	16	44	5	24	99.00
CTA 2560x1080 @25Hz (VIC 87)	152	2560	1080	3200	1125	192	41	44	5	25	90.00
CTA 2560x1080 @30Hz (VIC 88)	153	2560	1080	3520	1125	192	41	44	5	30	118.80
CTA 2560x1080 @50Hz (VIC 89)	154	2560	1080	3300	1125	192	41	44	5	50	185.62
CTA 2560x1080 @100Hz (VIC 91)	155	2560	1080	2970	1250	192	166	44	5	100	371.25
OVT 2560x1080 @30Hz	156	2560	1080	2784	1100	64	14	32	8	30	91.87
OVT 2560x1080 @60Hz	157	2560	1080	2720	1120	64	27	32	8	60	182.78
OVT 2560x1080 @120Hz	158	2560	1080	2656	1150	64	56	32	8	120	366.53
CVT 2560x1440 @60Hz	159	2560	1440	2640	1481	72	14	32	8	60	234.59
CVT 2560x1440 @60Hz	160	2560	1440	2720	1481	112	38	32	5	60	241.70
CVT 2560x1440 @144Hz	161	2560	1440	2720	1543	152	14	32	8	144	604.57
CVT 2560x1440 @200Hz	162	2560	1440	2720	1586	152	14	32	8	200	863.09
CTA 2560x1080 @48Hz (VIC 113)	163	2560	1080	3750	1100	192	16	44	5	48	198.00
CVT 2560x1080 @60Hz	164	2560	1080	3424	1120	704	37	272	10	60	230.09
CVT 2560x1080 @60Hz	165	2560	1080	2720	1111	112	28	32	10	60	181.32
CVT 2560x1080 @144Hz	166	2560	1080	2720	1157	152	14	32	8	144	453.33
CVT 2560x1080 @200Hz	167	2560	1080	2720	1190	152	14	32	8	200	647.59
CTA 2560x1080 @60Hz (VIC 90)	168	2560	1080	3000	1100	192	16	44	5	60	198.00
CTA 2560x1080 @120Hz (VIC 92)	169	2560	1080	3300	1250	192	166	44	5	120	495.00
DMT 2560x1600 @60Hz (DMT 0x4D)	170	2560	1600	3504	1658	752	55	280	6	60	348.58
DMT 2560x1600 @60Hz (DMT 0x4C)	171	2560	1600	2720	1646	112	43	32	6	60	268.63

OVT 2560x1600 @60Hz	172	2560	1600	2680	1660	64	40	32	8	60	266.93
CVT 2560x1920 @75Hz	173	2560	1920	3552	2006	776	83	280	4	75	534.25
OVT 2560x1920 @75Hz	174	2560	1920	2688	3280	64	1329	32	8	75	661.25
OVT 2728x1536 @60Hz	175	2728	1536	2880	1580	64	38	32	8	60	273.02
CVT 2728x1536 @60Hz	176	2728	1536	3720	1592	792	53	296	10	60	355.00
CTA 2880x240 @60Hz (VIC 12)	177	2880	240	3432	263	476	18	248	3	60	54.00
CTA 2880x240 @60Hz (VIC 13)	178	2880	240	3432	263	476	18	248	3	60	54.00
CTA 2880x288 @50Hz (VIC 27)	179	2880	288	3456	314	528	22	252	3	50	54.00
CTA 2880x288 @50Hz (VIC 28)	180	2880	288	3456	314	528	22	252	3	50	54.00
CTA 2880x480 @60Hz (VIC 10)	181	2880	480	3432	525	476	18	248	3	60	108.00
CTA 2880x480 @60Hz (VIC 11)	182	2880	480	3432	525	476	18	248	3	60	108.00
CTA 2880x480 @60Hz (VIC 35)	183	2880	480	3432	525	488	36	248	6	60	108.00
CTA 2880x480 @60Hz (VIC 36)	184	2880	480	3432	525	488	36	248	6	60	108.00
CTA 2880x576 @50Hz (VIC 37)	185	2880	576	3456	625	528	44	256	5	50	108.00
CTA 2880x576 @50Hz (VIC 38)	186	2880	576	3456	625	528	44	256	5	50	108.00
CTA 2880x576 @50Hz (VIC 25)	187	2880	576	3456	625	528	22	252	3	50	108.00
CTA 2880x576 @50Hz (VIC 26)	188	2880	576	3456	625	528	22	252	3	50	108.00
2880x1440 @60Hz	189	2880	1440	2976	1456	48	8	8	1	60	259.98
CVT 3440x1440 @60Hz	190	3440	1440	4688	1493	992	50	368	10	60	419.95
CVT 3440x1440 @60Hz	191	3440	1440	3600	1481	112	38	32	10	60	319.90
CVT 3440x1440 @60Hz	192	3440	1440	3520	1481	72	14	32	8	60	312.79
CVT 3440x1440 @120Hz	193	3440	1440	4800	1545	1064	102	384	10	120	889.92
CVT 3440x1440 @120Hz	194	3440	1440	3600	1525	112	82	32	10	120	658.80
CVT 3440x1440 @120Hz	195	3440	1440	3520	1525	72	14	32	8	120	644.16
CVT 3440x1440 @165Hz	196	3440	1440	4832	1588	1080	145	384	10	165	1266.08
CVT 3440x1440 @165Hz	197	3440	1440	3600	1559	112	116	32	10	165	926.05
CVT 3440x1440 @165Hz	198	3440	1440	3520	1559	72	14	32	8	165	905.47
CVT 3440x1440 @200Hz	199	3440	1440	4848	1622	1088	179	384	10	200	1572.69
CVT 3440x1440 @200Hz	200	3440	1440	3600	1586	112	143	32	10	200	1141.92
CVT 3440x1440 @200Hz	201	3440	1440	3520	1586	72	14	32	8	200	1116.54
CVT 3440x1440 @240Hz	202	3440	1440	4848	1663	1088	220	384	10	240	1934.93
CVT 3440x1440 @240Hz	203	3440	1440	3600	1619	112	176	32	10	240	1398.82
CVT 3440x1440 @240Hz	204	3440	1440	3520	1619	72	14	32	8	240	1367.73
CVT 3840x2160 @30Hz	205	3840	2160	4000	2191	112	28	32	5	30	262.92
CVT 3840x2160 @30Hz	206	3840	2160	3920	2191	72	14	32	8	30	257.66
CVT 3840x2160 @60Hz	207	3840	2160	4000	2222	112	59	32	5	60	533.28
CVT 3840x2160 @60Hz	208	3840	2160	3920	2222	72	14	32	8	60	522.61
CVT 3840x2160 @60Hz	209	3840	2160	4000	2222	152	14	32	8	60	533.47
CTA 3840x2160 @60Hz (VIC 97)	210	3840	2160	4400	2250	384	82	88	10	60	594.00
CTA 3840x2160 @24Hz (VIC 93)	211	3840	2160	5500	2250	384	82	88	10	24	297.00
CTA 3840x2160 @25Hz (VIC 94)	212	3840	2160	5280	2250	384	82	88	10	25	297.00
CTA 3840x2160 @30Hz (VIC 95)	213	3840	2160	4400	2250	384	82	88	10	30	297.00
CTA 3840x2160 @50Hz (VIC 96)	214	3840	2160	5280	2250	384	82	88	10	50	594.00
CTA 3840x2160 @24Hz (VIC 103)	215	3840	2160	5500	2250	384	82	88	10	24	297.00
CTA 3840x2160 @25Hz (VIC 104)	216	3840	2160	5280	2250	384	82	88	10	25	297.00
CTA 3840x2160 @30Hz (VIC 105)	217	3840	2160	4400	2250	384	82	88	10	30	297.00











CTA 3840x2160 @50Hz (VIC 106)	218	3840	2160	5280	2250	384	82	88	10	50	594.00
CTA 3840x2160 @60Hz (VIC 107)	219	3840	2160	4400	2250	384	82	88	10	60	594.00
CTA 3840x2160 @48Hz (VIC 114)	220	3840	2160	5500	2250	384	82	88	10	48	594.00
CTA 3840x2160 @48Hz (VIC 116)	221	3840	2160	5500	2250	384	82	88	10	48	594.00
CTA 3840x2160 @100Hz (VIC 117)	222	3840	2160	5280	2250	384	82	88	10	100	1188.00
CTA 3840x2160 @100Hz (VIC 119)	223	3840	2160	5280	2250	384	82	88	10	100	1188.00
CTA 3840x2160 @120Hz (VIC 120)	224	3840	2160	4400	2250	384	82	88	10	120	1188.00
OVT 3840x2160 @30Hz	225	3840	2160	3968	2200	64	27	32	8	30	261.89
OVT 3840x2160 @60Hz	226	3840	2160	3960	2240	64	54	32	8	60	532.22
OVT 3840x2160 @120Hz	227	3840	2160	3968	2300	64	111	32	8	120	1095.17
OVT 3840x2160 @144Hz	228	3840	2160	4000	2314	64	134	32	8	144	1332.86
OVT 3840x2400 @60Hz	229	3840	2400	3960	2480	64	60	32	8	60	589.25
OVT 4096x2160 @30Hz	230	4096	2160	4224	2200	64	27	32	8	30	278.78
CVT 4096x2160 @60Hz	231	4096	2160	4176	2222	72	14	32	8	60	556.74
CVT 4096x2160 @60Hz	232	4096	2160	4256	2222	112	59	32	10	60	567.41
CVT 4096x2160 @60Hz	233	4096	2160	4256	2222	152	14	32	8	60	567.61
CVT 4096x2160 @144Hz	234	4096	2160	4256	2314	152	14	32	8	144	1418.66
CTA 4096x2160 @60Hz (VIC 102)	235	4096	2160	4400	2250	216	82	88	10	60	594.00
CTA 4096x2160 @120Hz (VIC 219)	236	4096	2160	4400	2250	216	82	88	10	120	1188.00
CTA 4096x2160 @100Hz (VIC 218)	237	4096	2160	5280	2250	384	82	88	10	100	1188.00
CTA 4096x2160 @50Hz (VIC 101)	238	4096	2160	5280	2250	216	82	88	10	50	594.00
CTA 4096x2160 @48Hz (VIC 115)	239	4096	2160	5500	2250	384	82	88	10	48	594.00
CTA 4096x2160 @24Hz (VIC 98)	240	4096	2160	5500	2250	384	82	88	10	24	297.00
CTA 4096x2160 @25Hz (VIC 99)	241	4096	2160	5280	2250	216	82	88	10	25	297.00
CTA 4096x2160 @30Hz (VIC 100)	242	4096	2160	4400	2250	216	82	88	10	30	297.00

\*) TSI Timing ID





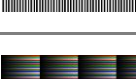
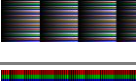
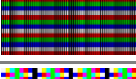





CVT: Coordinated Video Timings (CVT; VESA-2013-3 v1. 2); DMT: VESA and Industry Standards and Guidelines for Computer Display Monitor Timings; CTA: A DTV Profile for Uncompressed High Speed Digital Interfaces (CTA-861-H); UG: Unigraf proprietary timing

## APPENDIX D: PREDEFINED PATTERNS

### Fixed Patterns

Selection	Pattern	Description
Disabled		The links are activated but no video data transferred
Color Bar		100% intensity color bars of all primaries and mixed combinations.
Chessboard		8 by 8 chessboard with black (0%) and 100% intensity white
Solid Black		0% luminance
Solid White		100% white
Solid Red		100% red
Solid Green		100% green
Solid Blue		100% blue
White V-Strips		Vertical stripes of black (0%) and white (100%). Parameters set the widths of the black and white stripes in pixels respectively. Default black / white = 20 / 20 pixels. Parameter range 1 to 1000.
Gradient RGB Stripes		16 pixels high horizontal red, green, blue and white stripes. Intensity is increased from 0 to 100% with steps defined by the given parameter (Color Step = cs) and selected color. (step = cs*color_depth/256). "n" range 0 to 5000 (default 100).
Color Ramp		Color Ramp test pattern defined by VESA DisplayPort Link Layer Compliance Test Specification.
Color Square		Color Square test pattern defined by VESA DisplayPort Link Layer Compliance Test Specification. Color mode can be selected between RGB, YCbCr 4:4:4, 4:2:2, 4:2:0 (ITU Rec 601 / 709)
Motion Pattern		Horizontally moving color bar pattern. The pattern is shifted to left one pixel in each frame in a sequence. The length of the sequence is defined with parameter. Range 0 to 34 (default is 20)
Square Window		100% intensity white square horizontally and vertically centered. Height and width defined by parameter as the percentage of height and width of the frame (default 30).



















## Extended Patterns

Selection	Icon	Description
Select Image		Custom image uploaded by the user. Click on Select ... to browse.
Unigraf PM5544		Vpattern vector pattern based on PM5544
Color Web		Vpattern vector pattern.
Chinese Town Full HD		JPG Bitmap image (1920 x 1080 px)
UG-2111 HLG Narrow		Software generated pattern. HLG Narrow dynamic range.
UG-2111 PQ Narrow		Software generated pattern. PQ Narrow dynamic range.
UG-2111 PQ Full		Software generated pattern. PQ Full dynamic range.
Multi		Vpattern vector pattern. Multi-purpose pattern w square grid, cross-grids, 1x1 cross-hatches, circles, and color bars
SMPTE RP-133		Vpattern vector pattern based on SMPTE RP-133
SMPTE 303M		Vpattern vector pattern. SMPTE 303M; Full Range; RGB values before gamma correction based on D65 and PAL primaries
Blue		Vpattern vector pattern. 100% Blue
CirclesW		Vpattern vector pattern. Concentric circles
Complex		Vpattern vector pattern. Complex Pattern w 64 steps
Green		Vpattern vector pattern. 100% Green
Hor1W-Even		Vpattern vector pattern. Horizontal 1 px wide White bars in even rows
Hor1W-Odd		Vpattern vector pattern. Horizontal 1 px wide White bars in odd rows
Hor4W		Vpattern vector pattern. Horizontal 4 px high White bars
Hor10W		Vpattern vector pattern. Horizontal 10 px high White bars
Hor-10xB		Vpattern vector pattern. 10 pcs horizontal Blue bars
Hor-10G		Vpattern vector pattern. 10 pcs horizontal Green bars











## Extended Patterns (contd.)

Selection	Icon	Description
Hor-10xR		Vpattern vector pattern. 10 pcs horizontal Red bars
Hor-10xW		Vpattern vector pattern. 10 pcs horizontal White bars
HorRainbow-1024		Vpattern vector pattern. Horizontal Rainbow Ramps 1024 steps
HorRGBW-1024		Vpattern vector pattern. Horizontal RGBW Ramps 1024 steps
HorScale9		Vpattern vector pattern. Nine Horizontal Color Ramps
HorScaleW-64		Vpattern vector pattern. Horizontal White ramp 64 steps
HorScaleW-128		Vpattern vector pattern. Horizontal White ramp 128 steps
HorScaleW-X2		Vpattern vector pattern. Horizontal White ramp w edges 128 steps
InnerBox-BKtoB		Vpattern vector pattern. InnerBox pattern from Black to Blue
InnerBox-BKtoG		Vpattern vector pattern. InnerBox pattern from Black to Green
InnerBox-BKtoR		Vpattern vector pattern. InnerBox pattern from Black to Red
InnerBox-BKtoW		Vpattern vector pattern. InnerBox pattern from Black to White
InnerBoxMIX		Vpattern vector pattern. InnerBox pattern mixed hues.
InnerBox-RtoB		Vpattern vector pattern. InnerBox pattern from Red to Blue
Red		Vpattern vector pattern. 100% Red
Ver1W-Even		Vpattern vector pattern. Vertical 1 px wide White bars in even columns
Ver1W-Odd		Vpattern vector pattern. Vertical 1 px wide White bars in odd columns
Ver4W		Vpattern vector pattern. Vertical 4 px wide White bars
Ver10W		Vpattern vector pattern. Vertical 10 px wide White bars
Ver-10xG		Vpattern vector pattern. 10 pcs Vertical Blue bars
Ver-10xR		Vpattern vector pattern. 10 pcs Vertical Blue bars
Ver-10xB		Vpattern vector pattern. 10 pcs Vertical Blue bars
Ver-10xW		Vpattern vector pattern. 10 pcs Vertical Blue bars

## Extended Patterns (contd.)

Selection	Icon	Description
VerBars75%		Vpattern vector pattern. Vertical 75% intensity Color bars
VerBars100%		Vpattern vector pattern. Vertical 100% intensity Color bars
VerRGBW-1024		Vpattern vector pattern. Vertical RGBW Ramps 1024 steps
X-HatchBK-C		Vpattern vector pattern. Black 16 x12 Grid w Circle on White background
X-HatchW		White 16 x12 Grid on Black background
X-HatchW-C		White 16 x12 Grid w Circle on Black background
X-HatchW-CC		Vpattern vector pattern. White 16 x12 Grid w Ellipses, Circle and 100% color bars
Gray Box 10		China 5.6 White Window 10%
Gray Box 20		China 5.6 White Window 20%
Gray Box 30		China 5.6 White Window 30%
Gray Box 40		China 5.6 White Window 40%
Gray Box 50		China 5.6 White Window 50%
Gray Box 60		China 5.6 White Window 60%
Gray Box 70		China 5.6 White Window 70%
Gray Box 80		China 5.6 White Window 80%
Gray Box 90		China 5.6 White Window 90%
Gray Box 100		China 5.6 White Window 100%
8 Level Gray		China 5.5 Ultimate 8 Level Grayscale

## Extended Patterns (contd.)

Selection	Icon	Description
Black'n'White Window HDTV		China 5.8 Black and White Window(FOR HDTV)
Black'n'White Window SDTV		China 5.8 Black and White Window(FOR SDTV)
Black Line HDTV		China 5.10 Black Line
Black Line SDTV		China 5.10 Black Line SDTV
Black Window		China 5.7 Black Window
Check Board		China 5.9 Check Board
Line'n'Window		China 5.11 Line and Window
Narrow White Window		China 5.19 Narrow White Window
Single Dot		China Single Dot
White Line HDTV		5.10 White Line for HDTV
White Line SDTV		5.10 White Line for SDTV

More test patterns can be downloaded e.g. from [www.icdm-sid.org/downloads/testpatterns.html](http://www.icdm-sid.org/downloads/testpatterns.html).

# APPENDIX E: SINK AND SOURCE DUT TESTS

Source DUT Testing		Pro License	DP HDCP 2.3 CTS*	Electrical Testing
HDCP 2.3 CTS 1A Test Set DP RX (UCD-340)	HCDP2.3 CTS 1A-01 – HCDP2.3 CTS 1A-12		•	
HDCP 2.3 CTS 1B Test Set DP RX (UCD-340)	HCDP2.3 CTS 1B-01 – HCDP2.3 CTS 1B-10		•	
Audio Test Set (UCD-340)	Validate audio signal frequency and glitch-free audio reproduction	•		
CRC based Video Test Set (UCD-340)	CRC based single frame reference video test; CRC based single frame stability test; CRC based sequence of frames reference video test	•		
Electrical Test Set DP RX (UCD-340)	HPD test; Main Link test; AUX test			•
Link Config Tests (UCD-340)	Link Training at All Supported Lane Counts and Link Rates	•		
Pixel Level Video Tests (UCD-340)	Compare a defined number of captured frames to a single reference frame	•		
USBC Electrical Test Set (UCD-340)	Up Face Port CC and VCONN test; AUX (SBU) lines test; DUT as Power Sink; DUT as Power Source			•

Sink DUT Testing		Pro License	DP HDCP 2.3 CTS*	Electrical Testing
HDCP 2.3 CTS 2C Test Set DP TX (UCD-340)	HCDP2.3 CTS 2C-01 – HCDP2.3 CTS 2C-06		•	
USBC Electrical Test Set (UCD-340)	Up Face Port CC and VCONN test; AUX (SBU) lines test; DUT as Power Sink; DUT as Power Source			•

## Test Report

Results of the test can be saved as a report in HTML format. The report file can be viewed with any HTML browser. The report has built-in views for Report Summary, Test Summary, and individual Test Logs.

The user can add details of the DUT, test situation and other remarks to the report.

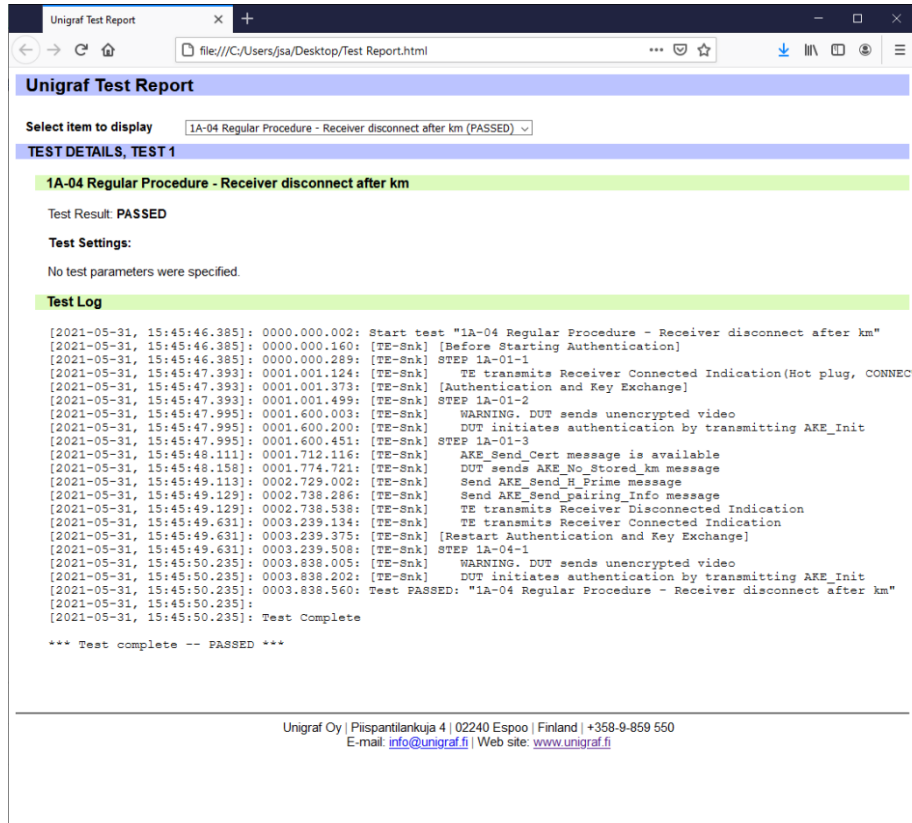

## Audio Test Set – DP Alt Mode Rx

Role:	Product:
DP Reference Sink (DP RX)	UCD-340

### Validate audio signal frequency and glitch-free audio reproduction

Perform frequency check on the digital audio content and verify the content to be glitch-free. This test assumes that a pure sine-wave audio signal content is being transmitted to the test equipment.

The test will first capture minimum of one second of audio content. The audio is then analyzed in two stages.

First, the power spectrum is calculated, and the highest peak must be within the defined window. Resolution of the peak frequency check is better than  $\pm 1$  Hz.

In the second stage, received audio is checked for random glitches, such as dropped or duplicated samples.

The test is considered passed if power of audio content spectrum has its maximum within the defined window, and the number of detected audio glitches does not exceed programmed limit.

Name	Value
Expected sampling rate of audio signal	44100
Expected audible (sine) frequency as Hz	1000
Allowed deviation from expected frequency as Hz	1
The percentage deviation from the ideal sine	5
Number of audio glitches allowed per test	0
Tested audio save conditions	Save none
Location where the captured audio is to be saved	0

### Parameters in use

- Expected sampling rate of audio signal (default 44 100 s/sec)
- Expected audible (sine) frequency in Hz (default 1000 Hz)
- Allowed deviation from expected frequency in Hz (default 1 Hz)
- The percentage deviation from the ideal sine (default 5)
- Number of audio glitches allowed per test (default 0)
- Tested audio save conditions: save none, save failed, save all (default Save none)
- Location where the captured audio is to be saved. Double click the select folder. (default 0)

## CRC Video Tests –DP Alt Mode Rx

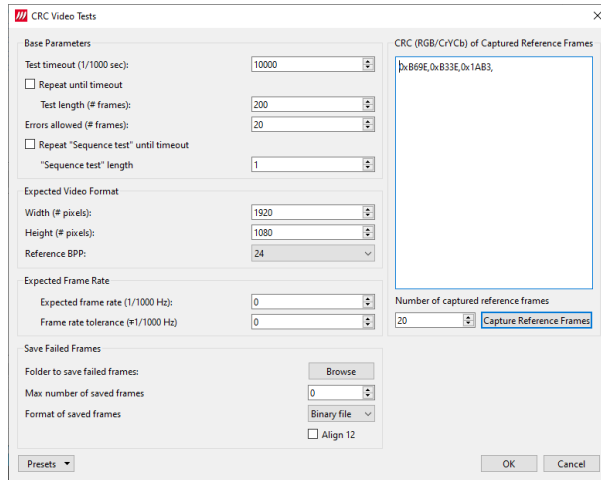

Role:	Product:
DP Reference Sink (DP RX)	UCD-340
Test timeout:	If enabled test will abort when the time has elapsed
Repeat until timeout:	Enable "Test timeout"
Test length (# frames):	Number of captured frames to test
Errors allowed (# frames):	Number of failing frames allowed before test is Fails
Repeat "Sequence test" until timeout:	Repeat test sequence until the timeout set
"Sequence test" length (# of repeats):	Repeat the sequence
Expected video format	Format of the signal expected. Width, height and reference BPP.
Expected frame rate	Expected frame rate and frame rate tolerance.
Number of captured reference	Number of frames stored as reference
Capture Reference Frames	Capture reference frames for the test
Folder to save failed frames:	PC folder where failed frames are stored.
Maximum number of save frames:	Maximum number of failed frames stored to PC
Format of saved frames	Select the format of saved frames
Presets:	Store and recall settings

### CRC Based Single Reference Frame Video Test

The test compares captured frames to a provided reference.

TE compares the video mode (Frame Width, Height, BPP and optionally Frame rate) to provided parameters and after that captures frames and compares the CRC (check sum) of their three color components to the provided reference until the number of bad frame limit provided is detected or the provided total number of frames is reached.

The test is judged FAIL if video mode does not match, or the number of bad frames is exceeded.

The test optionally captures the failed frames as bitmap images and stores them into the hard disc.

#### Parameters in use

- Test Timeout (default 10 000 ms)
- Test lengths (default 200 frames)
- Errors allowed (default 20)
- Sequence test length (default 1)
- Expected video format
  - Width (default 1920)
  - Height (default 1080)
  - Reference BPP (default 24)
- Expected frame rate
- Frame rate tolerance

### CRC Based Single Frame Video Stability Test

The test verifies that the captured video is stable.

TE captures a frame and sets the CRC of its color components as reference. After that TE captures frames and compares their CRC (check sum) to the reference until the number of bad frame limit provided is detected or the provided total number of frames is reached.

The test is judged FAIL if the number of bad frames is exceeded.

The test optionally captures the failed frames as bitmap images and stores them into the hard disc.

#### Parameters in use

- Test Timeout (default 10 000 ms)
- Test lengths (default 200 frames)
- Errors allowed (default 20)

### CRC Based Sequence of Reference Frames Test

The verifies that a sequence of frames is captured in the right order.

TE compares the video mode (frame Width, Height, BPP and optionally Frame rate) to provided parameters. After that captures frames to find a frame with matching CRC (check sum) of their three color components to the first provided reference. After the first matching CRC is found it compares the CRC of the following frames until the Number of frames tested parameter is reached.

The test is judged FAIL if video mode does not match, the first frame in the list is not found or the CRC of the following frames do not match the provided list.

The test optionally captures the failed frames as bitmap images and stores them into the hard disc.

#### Parameters in use

- Test Timeout (default 10 000 ms)
- Test lengths (default 200 frames)
- Expected video format
  - Width (default 1920)
  - Height (default 1080)
  - Reference BPP (default 24)
- Expected frame rate
- Frame rate tolerance

---

**Note:** Please note that in order for the TE to maintain the sequence, all CRCs in the reference frame list should be different.

---

### CRC Based Continuous Sequence of Reference Frames Test

The verifies that a sequence of frames is captured in the right order many times repeatedly.

TE compares the video mode (frame Width, Height, BPP and optionally Frame rate and Color format) to provided parameters. After that captures frames to find a frame with matching CRC (check sum) of their three color components to the first provided reference. After the first matching CRC is found it compares the CRC of the following frames until the Number of frames tested parameter is reached. After that it resets the list and starts from the first CRC. The list is repeated until timeout or until the provided number of repetitions is reached.

The test is judged FAIL if video mode does not match, the first frame in the list is not found or the CRC of the following frames do not match the provided list.

The test optionally captures the failed frames as bitmap images and stores them into the hard disc.

#### Parameters in use

- Test Timeout (default 10 000 ms)
- Test lengths (default 200 frames)
- Errors allowed (default 20)
- Sequence test length (default 1)
- Expected video format
  - Width (default 1920)
  - Height (default 1080)
  - Reference BPP (default 24)
- Expected frame rate
- Frame rate tolerance

---

**Note:** Please note that in order for the TE to maintain the sequence, all CRCs in the reference frame list should be different.

---

## USB-C Electrical Test Set – DP Rx, DP Tx

Role:	Product:
DP Alt Mode Reference Source (DP TX)	UCD-340 with Unigraf Electrical Test Cable
DP Alt Mode Reference Sink (DP RX)	UCD-340 with Unigraf Electrical Test Cable

Electrical Tests verify the continuity of the interface signals and the voltage levels applied by the driving electronics.

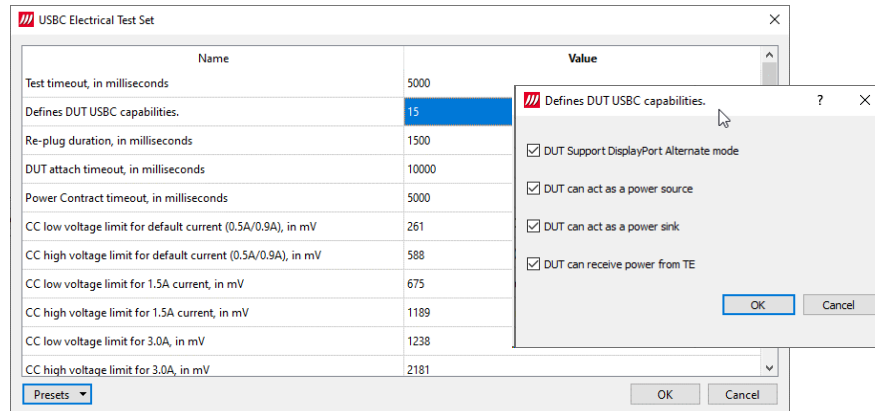

### Up Face Port CC and Vconn Test

This test verifies operation of CC lines for short-circuit and open-circuit failures, and that hardware directly related to CC lines is working properly. During the test, TE will operate as Type-C UFP device.

In the start of the test TE temporarily disconnects the CC lines to simulate a re-plug event.

After the re-plug event, Ra is connected to CC2, and Rd is connected to CC1. DUT is expected to have Rp, or a current source applied to both CC1 and CC2 lines. The impedance of DUT's Rp resistor, or current source must be adjusted so that the voltage drop on Rd resistor in TE is within one of the voltage ranges defined by the provided parameters. TE will measure the voltage drop on Rp.

Once DUT has started to provide Vconn on CC2, TE will measure the voltage present on CC2. After that TE will do a cable-flip and repeat the steps as above.

For a PASS result, measured values from CC1, CC2 and Vconn must be within ranges defined by the provided parameters.

---

**Note:** Configuration items for this test should be programmed with averaged values from several "golden sample" DUT's.

---

**Important:** In order to run this test with UCD-340, **Unigraf Electrical Test Cable** must be used, and Electrical Testing feature enabled with a corresponding license.

---

#### Parameters in use

- Test timeout (default 5 000 ms)
- R-plug duration (default 1 500 ms)
- DUT attach timeout (default 10 000 ms)
- CC low voltage limit for default current (0.5/0.9A) (default 261 mV)
- CC high voltage limit for default current (0.5/0.9A) (default 588 mV)
- CC low voltage limit for 1.5A current (default 675 mV)
- CC high voltage limit for 1.5A current (default 1 189 mV)
- CC low voltage limit for 3A current (default 1 238 mV)
- CC high voltage limit for 3A current (default 2 181 mV)
- Vconn low voltage limit (4 750 mV)
- Vconn high voltage limit (5 500 mV)

### AUX (SBU) Lines Test

This test verifies operation of SBU lines for short-circuit and open-circuit failures and that hardware directly related to SBU lines is working properly. During the test the TE will operate as Type-C UFP device. For this test, DUT must support DisplayPort Alternate Mode.

In the start of the test TE temporarily disconnects the CC lines to simulate a re-plug event and waits for DUT to enter DP Alternate mode.

Once DUT has entered the DP alternate mode, TE will measure voltage levels on SBU1 (AUX+) and SBU2 (AUX-) lines. Please notice that if TE is acting as DP Sink, it will de-assert HPD signal to keep AUX bus at IDLE state during the voltage measurements.

Once the voltages are measured, TE will do a cable-flip and repeat the steps as above.

For a PASS result, the measured voltages must be within the ranges defined by the provided parameters.

---

**Note:** Parameters for this test should be programmed with averaged values from several “golden sample” DUT’s.

---



---

**Important** In order to run this test with UCD-340, **Unigraf Electrical Test Cable** must be used, and Electrical Testing feature enabled with a corresponding license.

---

#### Parameters in use

- Test timeout (default 5 000 ms)
- DUT Capabilities flags (default 7)

Bits	Description
0	DUT Support for DisplayPort Alt Mode (1 Yes, 0 No)
1	DUT can act as power source (1 Yes, 0 No)
2	DUT can receive power from TE (1 Yes, 0 No)
3	DUT support for Power Delivery Contract (1 No, 0 Yes)
31:4	Reserved

- R-plug duration (default 1 500 ms)
- DUT attach timeout (default 10 000 ms)
- DP Alt Mode timeout (default 5 000 ms)
- DP Alt Mode AUX+ line idle low voltage (default 100 mV)
- DP Alt Mode AUX+ line idle high voltage (default 600 mV)
- DP Alt Mode AUX– line idle low voltage (default 2 500 mV)
- DP Alt Mode AUX– line idle high voltage (default 3 000 mV)

### DUT as Power Sink

This test verifies operation of Vbus and GND lines for short-circuit and open-circuit failures. The test is performed using mandatory PDO for power contract. During the test, the TE will operate as power source, and advertise only **vSafe5V** for power contract. In order to run this test, the DUT must support Power Sink role.

In the start of the test TE temporarily disconnects the CC lines to simulate a re-plug event and waits for Power Contract to be established.

After Power Contact has been established TE will wait for the delay stated in *Measurement delay* parameter and measures the current in Vbus and GND lines and the voltage of Vbus. The purpose of the delay is to allow the DUT time to stabilize its power consumption.

---

**Note:** The test assumes that the current flows through the four separate Vbus and GND lines evenly. Since current measurements are done sequentially, any variance in DUT power consumption during the measurement can cause this test to fail.

---

Total currents are calculated for Vbus, and for GND. The difference in the measured values of the four connections may not exceed the programmed deviation limits.

For PASS result, the measured Vbus voltage, Vbus current and GND line current must be within the ranges defined by provided parameters.

---

**Important:** In order to run this test with UCD-340, **Unigraf Electrical Test Cable** must be used and Electrical Testing feature enabled with a corresponding license.

---

#### Parameters in use

- Test timeout (default 5 000 ms)
- DUT Capabilities flags (default 7)

Bits	Description
0	DUT Support for DisplayPort Alt Mode (1 Yes, 0 No)
1	DUT can act as power source (1 Yes, 0 No)
2	DUT can receive power from TE (1 Yes, 0 No)
3	DUT support for Power Delivery Contract (1 No, 0 Yes)
31:4	Reserved

- R-plug duration (default 1 500 ms)
- DUT attach timeout (default 10 000 ms)
- Power Contract timeout (default 10 000 ms)
- Vbus voltage low limit (default 4 750 mV)
- Vbus voltage high limit (default 5 500 mV)
- Vbus current deviation (between wires) (default 100 mA)
- Return (GND) current deviation (between wires) (default 100 mA)
- Measurement delay (default 2 000 ms)
- Minimal current (default 20 mA)

### DUT as Power Source

This test verifies operation Vbus and GND lines for short-circuit and open-circuit failures. During the test, TE will operate as power sink and selects only **vSafe5V** PDO for power contract. In order to run this test, the DUT must support Power Source role.

In the start of the test TE temporarily disconnects the CC lines to simulate a re-plug event and waits for Power Contract to be established

After Power Contact has been established TE will wait for the delay stated in *Power measurement delay* parameter and measures the current in Vbus and GND lines and the voltage of Vbus. The purpose of the delay is to allow the DUT time to stabilize its power consumption.

---

**Note:** The test assumes that the current flows through the four separate Vbus and GND lines evenly. Since current measurements are done sequentially, any variance in DUT power consumption during the measurement can cause this test to fail.

---

Total currents are calculated for Vbus, and for GND. The difference in the measured values of the four connections may not exceed the programmed deviation limits.

For PASS result, the measured Vbus voltage, Vbus current and GND line current must be within the ranges defined by provided parameters.

---

**Important** In order to run this test with UCD-340, **Unigraf Electrical Test Cable** must be used and Electrical Testing feature enabled with a corresponding license.

---

### Parameters in use

- Test timeout (default 5 000 ms)
- DUT Capabilities flags (default 7)

Bits	Description
0	DUT Support for DisplayPort Alt Mode (1 Yes, 0 No)
1	DUT can act as power source (1 Yes, 0 No)
2	DUT can receive power from TE (1 Yes, 0 No)
3	DUT support for Power Delivery Contract (1 No, 0 Yes)
31:4	Reserved

- R-plug duration (default 1 500 ms)
  - DUT attach timeout (default 10 000 ms)
  - Power Contract timeout (default 10 000 ms)
  - Vbus voltage low limit (default 4 750 mV)
  - Vbus voltage high limit (default 5 500 mV)
  - Vbus current deviation (between wires) (default 100 mA)
  - Return (GND) current deviation (between wires) (default 100 mA)
- Measurement delay (default 2 000 ms)

## Link Config Tests – DP Rx

Role:	Product:
DP Reference Sink (DP RX)	UCD-340

Name	Value
Test timeout, in milliseconds	5000
Max lanes count supported by DUT	4
Max lane rate supported by DUT	5.4 Gbps
Long HPD pulse duration, in milliseconds	1000
Link training start timeout, in milliseconds	5000
Delay between test cycles, in milliseconds	3000
Reserved	0

### Link Training at All Supported Lane Counts and Link Rates

Test requests link training on all supported lane counts and link rates. Each link training must be successfully completed in order to pass the test.

#### Parameters in use

- Test Timeout (default 5 000 ms)
- Max lane count supported by DUT (default 4)
- Max lane rate supported by DUT as multiple of 0.27 Gbps. (valid settings 6, 10 and 20; default 20)
- Long HPD pulse duration (default 1 000 ms)
- Link training start timeout (default 5 000 ms)
- Delay between test cycles (default 3 000 ms)

## Pixel Level Video Tests – DP Rx

Role:	Product:
DP Reference Sink (DP RX)	UCD-340

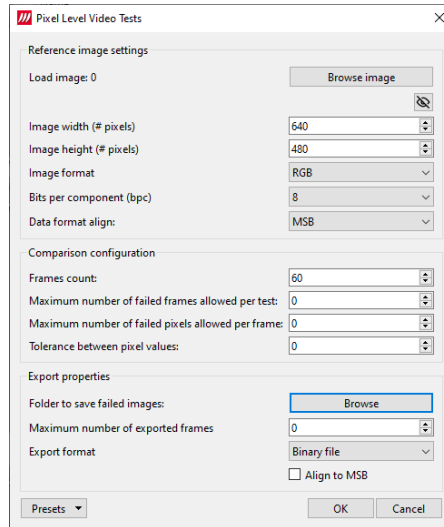

### Compare a defined number of captured frames to a single reference frame.

The test will capture the required number of consecutive frames into system RAM and then perform analysis between each frame and reference frame. Test is considered passed if the number of failed frames does not exceed the programmed value.

#### Parameters in use

<i>Load image:</i>	Load the reference image
<i>Image resolution (#pixels): width and height</i>	Video resolution expected
<i>Image format:</i>	Image format expected
<i>Bits per component:</i>	Bits per component expected
<i>Data format align:</i>	Video data format expected (MSB, LSB)
<i>Frames count:</i>	Number of frames buffered for testing
<i>Maximum number of failed frames allowed per test:</i>	Number of failed frames allowed totally
<i>Maximum number of failed pixels allowed per frame:</i>	Number of failed pixels allowed per buffered frame
<i>Tolerance between pixel values:</i>	The allowed difference between a color component of pixel in the captured frame to the reference bitmap.
<i>Folder to save failed images:</i>	PC folder where failed frames are stored.
<i>Maximum number of exported frames:</i>	Maximum number of failed frames stored to PC
<i>Export format</i>	Binary file, PPM image or BMP image
<i>Presets:</i>	Store and recall settings

## APPENDIX F: VPATTERN LANGUAGE

### General

The Vpattern definition language (in the following simply “VTP”) is a straightforward yet flexible way of describing test patterns for UCD Generators. This description is providing an introduction and examples of the most usable instructions and parameters.

The VTP language uses text command syntax. Each row represents one drawing instruction. The coordinate system can be either absolute or scaled. In the absolute mode the actual pixel position is referred while in the scaled mode the coordinates refer to the “Drawing resolution” used while drawing. For both absolute and scaling coordinates the origin is the upper left hand corner of the screen.

### Terminology

The following terms are used in this document:

*Coordinate system*: two numerical ranges of integer, positive numbers. E.g. {0,799},{0,599} or {0,10000},{0,10000}.

*Coordinates*: a tuple of integer, positive numbers used to address a position on an image, e.g. (100,250). The first number is the horizontal position, the second one the vertical position. The actual position is always related to the coordinate system currently in use

*Drawing resolution*: the width and height of the space that can be used for drawing, expressed in pixels. E.g., 2560 by 1600.

*Drawing area*: a 2-dimensional area spanning all of the drawing resolution, expressed in the current coordinate system notation. E.g., if the drawing resolution is 800 x 600 pixels, the drawing area includes all points (x,y) where x = 0 to 799 and y = 0 to 599 in ABSOLUTE mode or x = 0 to 10000 and y = 0 to 10000 in SCALED mode.

### Notation

The following notation is used in this document:

- A token is enclosed by characters ‘<’ and ‘>’. For instance, <variable> represents a generic variable.
- Different legal choices for a command parameter are separated by character ‘|’. For instance, <variable> | <number> means that either variable or number can be used as parameters.
- Items that can be repeated 0, 1 or more times are preceded by ‘{’ and followed by ‘}’\*. For instance {<number>}\* means zero, one or more occurrences of a number.

### Syntax rules

The following general syntax rules apply to VTP language files:

- The VTP is a text-based, interpreted language
- Commands, variables, and constant names are not case-sensitive.
- All text at the right of a semicolon (;) is treated as comment.
- All strings are delimited by quotation marks (“a string”). Quote and backslash characters must be prefixed by the backslash symbols (“ a quote \” and a backslash \\”).
- Filenames cannot contain pathnames.

## Commands

### Scaling commands

All drawing commands using coordinates can refer either to absolute or scaled coordinates. The absolute coordinate system starts at 0 and its measurement unit is the pixel (vertically the line). It extends up to the maximum drawing resolution in use minus one, expressed in pixels too.

Conversely, the scaled coordinate system ranges from 0 to 10000, independently from the drawing resolution. Its measurement unit is thus a flexible, virtual pixel.

Absolute coordinates provide the fastest drawing speed, but they are resolution specific. Scaled coordinates are resolution independent while introducing a slight speed penalization.

For both systems, the origin (0,0) refers to the upper left hand corner of the screen.

#### ABSOLUTE

```
Syntax: ABSOLUTE
```

This command is normally used in the beginning of the VTP file. All drawing commands issued after ABSOLUTE will have absolute coordinate values, i.e., their coordinates will be interpreted as pixels and lines.

The allowed coordinate values are from 0 to the maximum drawing resolution minus one. For instance, for a drawing resolution of 2560 x 1600 pixels, the allowed coordinate range (x,y) for x is 0 to 2559 and for y 0 to 1599.

Constants MAXX and MAXY can be used in place of the numeric values to achieve basic scaling capabilities.

#### SCALED

```
Syntax: SCALED
```

All drawing commands issued after the SCALED command will have their coordinates interpreted as within a range from 0 to 10000 (10001 possible coordinate values), regardless of the current drawing resolution. Positioning can be calculated as percentages. If you wanted to address a point at 50% of the drawing resolution, then you would use the number 5000. If you wanted 75% you would simply use the 7500.

### Graphics Drawing Commands

All of the following graphics drawing commands use the currently selected foreground color for shape perimeter and filling.

#### LINE

```
Syntax: LINE x1 y1 x2 y2
```

Draws a line from point (x1,y1) to point (x2,y2).

Example:

You can draw a white diagonal cross using either ABSOLUTE and SCALED coordinate mode and get the same result.

```
ABSOLUTE ; Set scaling mode to absolute
COLORDEPTH 8 ; 8 bits per color
COLORRGB 255 255 255 ; white
LINE 0 0 MAXX MAXY ; Draw a line from upper left to lower right corner
LINE 0 MAXY MAXX 0 ; Draw a line from lower left to upper right corner
Or if you want a fixed size for 640 x 480 resolution
LINE 0 0 639 479
LINE 0 479 639 0
```

The pattern will look like this:

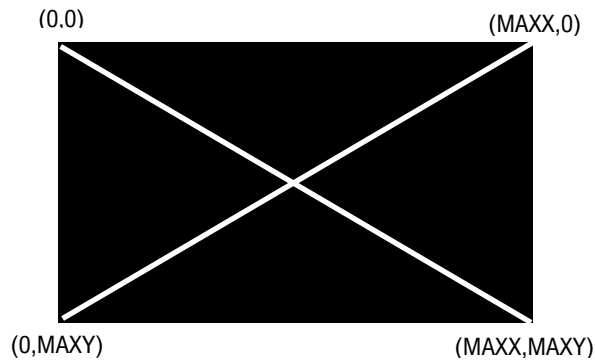

Using SCALED instead of ABSOLUTE.

```
SCALED
COLORDEPTH 8
COLORRGB 255 255 255
LINE 0 0 10000 10000
LINE 0 10000 10000 0
```

### BOX

```
Syntax: BOX x1 y1 x2 y2
```

Draws a filled rectangle with upper left corner (x1,y1) and lower right corner (x2,y2).

Example:

This code will create a full white screen with all resolutions.

```
SCALED
COLORDEPTH 8
COLORRGB 255 255 255
BOX 0 0 10000 10000
```

### DOT

```
Syntax: DOT x y
```

Draws a single dot at location (x,y).

### FILL

```
Syntax FILL x y
```

Initiates a flood fill (or seed fill) with foreground color starting from position (x,y).

### CIRCLE

```
Syntax: CIRCLE x y r
```

Draws a circle with center point at (x,y) and radius r. Please, note that when using SCALED coordinates radius r is expressed as a vertical measure.

Example:

```
SCALED
COLORDEPTH 8
COLORRGB 255 255 255
CIRCLE 5000 5000 50
```

The pattern will look like this:

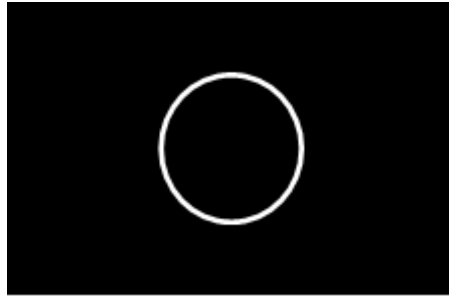

### FCIRCLE

Syntax: FCIRCLE x y r

Draws a circle with center point at (x,y) and radius r. Filled with foreground color. Please, note that when using SCALED coordinates radius r is expressed as a vertical measure.

The pattern will look like this:

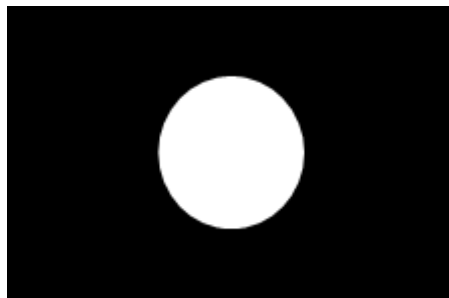

### ELLIPSE

Syntax: ELLIPSE x y hr vr

Draws an ellipse with center point at (x,y), horizontal radius hr and vertical radius vr.

You can use ELLIPSE instead of CIRCLE for example when the displayed pixel is not square for compensating the stretching.

Example:

```
SCALED
COLORDEPTH 8
COLORRGB 255 255 255
ELLIPSE 5000 5000 3000 4000
```

The pattern will look like this:

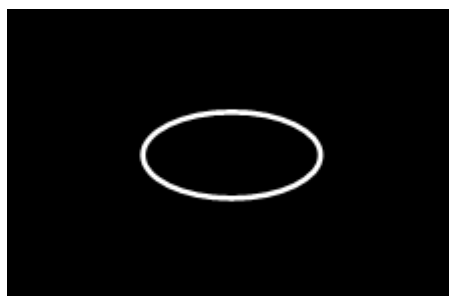

## Text Drawing Commands

All of the following commands use the currently selected foreground color for the “foreground” pixels of the font and the currently selected background color for “background” pixels.

### TEXTPOS

```
Syntax: TEXTPOS x y
```

Sets the text drawing position to point (x,y).

### TEXT

```
Syntax: TEXT <string> | <var> | <const> { <string> | <var> | <const> }*
```

The command executes a CR and LF (carriage return and line feed) and then draws a text string <string>, a variable <var>, a constant <const> or a combination of them starting from the current text position.

<string> parameter is a quoted sequence of characters. If the string contains a quote character (") or a backslash character (\) then it must be preceded with a back slash character (\).

<var> is a parameter variable (A – Z, MAXX, MAXY) defined by SET command.

<const> one of the Timing Variables. Timing variables are defined by currently loaded timing parameters. Please refer to Chapter 3.

---

#### Note:

Please note that when using the timing parameters in a pattern the display will be redrawn every time the timing is changed. Normally the VTG does not have to redraw the picture when only e.g., the horizontal sync is changed, but if the HS variable is used in the pattern it needs to be updated to display the new value.

---

Example:

```
ABSOLUTE
COLORDEPTH 8
COLORRGB 255 255 255
TEXTPOS 100 100 ; Text starting point 100 pixels from left edge and 100 display
lines down from top
TEXT "HRES=" HR " PIXELS ; This will draw the text HRES then the
variable HR value and PIXELS
TEXT "Quote character \" and backslash \\"
```

## Program Flow Commands

### REPEAT

Syntax: REPEAT <variable> a b s

All commands after between REPEAT and END command are repeated the number of times defined by <variable>. <variable> is set to value a before starting the first iteration loop. At the end of each iteration, variable is incremented by s (variable = variable + s). The REPEAT is terminated when variable reaches or exceeds value b, and the execution continues from the command following the END command. For example:

```
SCALED
COLORDEPTH 8
COLORRGB 255 255 255
REPEAT W 0 10000 200
LINE W 0 W 10000
END
```

A maximum of 2 REPEAT loops can be nested (placed inside each other).

### END

Syntax: END

This command follows a REPEAT command and defines a group of instructions to be repeated.

## Color Commands

The user can assign the used colors in two basic ways: either by giving the actual Red, Green and Blue (or R, G and B) color component values or using pre-defined color palettes. The first method is referred as True Color Mode and the latter as Palette Mode.

In True Color Mode the numerical values given for R, G and B will be the actual output signal intensity values for the pixel in question. The numerical color value in Palette Mode will act as an address (or index) to a pre-defined color in a 256 color table. The output signal intensity will be the R, G and B value entry in the cell where the address points to.

Palette mode can only be used with True Color Mode is .

### COLORDEPTH

Syntax: COLORDEPTH n

The command is used in True Color Mode (COLORMODE 2), to define the number of bits used for each color component (R, G and B) of the data to be displayed. Possible values for the parameter n are 6, 8, 10 and 12. If COLORDEPTH command is not used, 10 bits per color is used.

Example: To display a bitmap that uses 8 bits for r, g and b (24-bit colors) you have to use COLORDEPTH 8.

Command	Nr of color bits	Range of values for R, G and B
COLORDEPTH 6	18	0 to 63
COLORDEPTH 8	24	0 to 255
COLORDEPTH 10	30	0 to 1023
COLORDEPTH 12	36	0 to 4095

COLORDEPTH can be used only once in a VTP file, and it has to be placed before all drawing instructions it is supposed to affect.

## COLORRGB

```
Syntax: COLORRGB r g b
```

The command defines the foreground color used for the following drawing commands. The command is used in True Color Mode only.

The range of values for r, g and b depends on the bits per color used. If not changed with COLORDEPTH command, 10 bits per color is used. Please refer to COLORDEPTH command for range of values.

## Various Commands

### SET

```
Syntax: SET <variable> n
```

Assigns value n to programming variable called variable. n must be a positive number or zero.

## Variables

### Timing Variables

Timing Variable	Value name
HF	Drawing resolution horizontal size minus one
HP	Drawing resolution vertical size minus one
HR	Current timing horizontal frequency (MHz?)
HA	Current timing horizontal period (pixels)
HS	Current timing horizontal resolution (pixels)
HBP	Current timing horizontal active time (pixels)
HFP	Current timing horizontal sync length (pixels)
VF	Current timing horizontal back porch length (pixels)
VP	Current timing horizontal front porch length (pixels)
VR	Current timing vertical frequency (MHz?)
VA	Current timing vertical period (lines)
VS	Current timing vertical resolution (lines)
VBP	Current timing vertical active time (lines)
VFP	Current timing vertical sync length (lines)
PF	Current timing vertical back porch length (lines)
HLB	Current timing vertical front porch length (lines)
HRB	Pixel frequency (Mpps?)
VTB	Drawing resolution horizontal size minus one
VBB	Drawing resolution vertical size minus one

### Expressions

Any command numeric parameter can be replaced by an expression, according to the syntax below:

`<term> ::= <variable> | <constant> | <number>`

`<expression> ::= <term> { '+' | '-' | '*' | '/' | '%' } <term>`

`<parameter> ::= <term> | <expression>`

Some example of legal parameter values:

```

B
MAXX
342
B + MAXX
B / 2
B * C

```

Expressions have always positive integers or zero value. When an expression evaluates to a negative value, it is set automatically to zero. Number values are also always positive integers or zero.

## Assignments

A variable can be assigned a numerical value by using the SET command.

The second parameter of the SET command can be replaced by an expression thus allowing commands like those here below:

```
SET C B+MAXX
```

```
SET K K+1
```

```
SET K A+B
```

## Default state at VTP execution startup

Coordinate system: ABSOLUTE

Foreground color: 1023 1023 1023

Background color: 0 0 0

Output image is cleared (all black)

All variables are initialized to zero

```
COLORDEPTH 10
```

# APPENDIX H: PLAYLISTS AND SCENARIOS

UCD Console's Playback enables you to run scripts called playlists. Use playlists to stream video, audio and metadata.

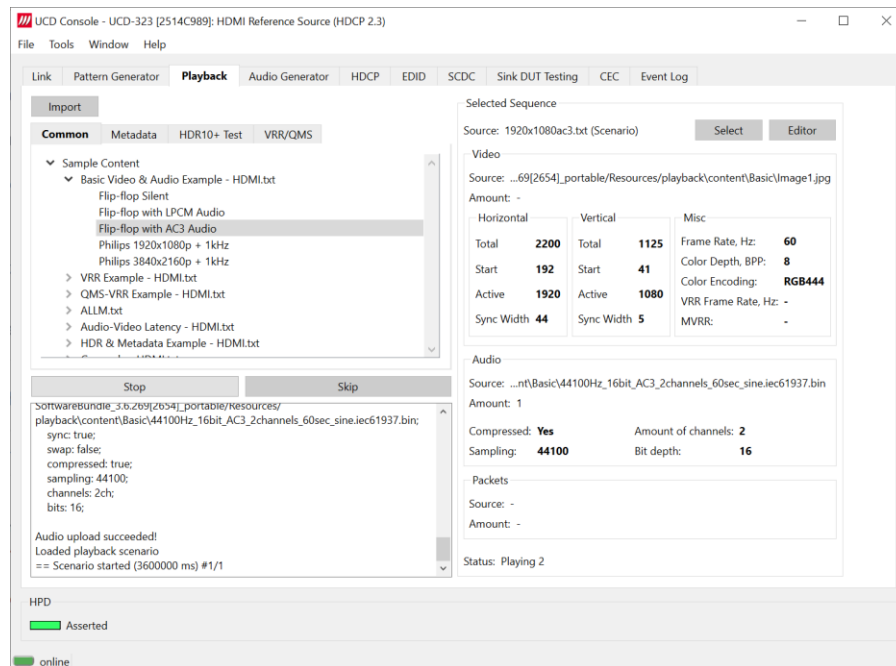

## Playlist

A *Playlist* is a text script consisting of a *[Device]* block and *[Scenario]* block(s). A *[Device]* block lists the serial number of the device and *connectortype* (such as a displayport transmitter). *[Scenarios]* blocks have a *caption* (which are used to display sample content), a period (*Scenario* duration in milliseconds) and a relative path to a script text file (ex. Scenario\_PSR1\_Entry\_N.txt). Scenarios are played in sequence.

## Scenario

A *scenario* is a script text file to specify a sequence of video frames, metadata packets and audio to be transmitted.

## Frame Memory

When played, all content is first loaded to the frame memory buffer of the UCD device. This enables smooth transition between content items during execution of the Scenario.

The size of frame buffer memory sets a limit for content that can be played. In their default configuration UCD devices feature a 2 GBytes frame buffer memory. This frame buffer enables loading up to 40 pcs 4K video frames or 10 pcs 8K video frames.

## Sample Content

UCD Console's Playback tab features a set of sample content. These examples can be used as a basis for creating custom test sequences. The sample content is stored as files by default in `C:\Program Files\Unigraf\Unigraf UCD Tools\Resources\playback\content`. It is advisable to create copy of the installed original files and edit the copies.

See [Sample Content](#) later in this Appendix.

## Playlists

A *playlist* defines the UCD device to be used and the output destination for transmission. It lists *scenarios* the played (video and audio sequences including metadata) to be transmitted and their duration.

**Note:** *Playlists* and *Scenarios* are technology dependent. Metadata (or packets) differ for HDMI and DisplayPort Device section

### Device block

*Device* block describes the device and output connector type.

Key	Description	Possible values
[Device]	Required. Start of the Device block.	
serialnumber	Required. Specifies serial number of the UCD device. The '*' wildcard can be used if only one UCD source device is connected to the PC.	'*' '1722C333'
connectortype	Required. Specifies output connector to be used. Playlist cannot contain scenarios for different connector types.	'DisplayPort Out' 'USBC Out'

### Scenario block

Section describes selected scenario and its playback parameters. Playlist runs scenarios in the order they are listed.

Key	Description	Possible values
[Scenario]	Required. Start of a Scenario section. Playlist can have multiple Scenario sections.	
caption	Optional. Title of the Scenario. Any character string accepted.	'Scenario 1' 'Playlist completed'
path	Required. Specifies relative path to scenario file.	Any path
period	Required. Duration of Scenario in msec. The duration is ignored if close-after-upload is set to '1'.	'60000' '5000'
close-after-upload	Optional. When set to '1', command line version of the Playback tool will exit after loading scenario content and starting playback.	'0' or '1' Default '0'
execute-after-upload	Optional. Executes provided command in cmd.exe or bash and waits for its completion. Calculation of 'period' starts after the command is executed.	'script.bat && dir' 'rmdir '/home/user/test'

## Scenarios

A Scenario is text file for specifying a specific sequence of video frames, events (packets) and audio to be played in order. *Scenarios* also set up the device state for transmission.

## Parameters

Scenario parameters are defined below.

Scenario ite	Description
video	Relative path format of video frame files
audio	Relative path of the audio file
packets	Relative path of metadata packet files
porder	Play order. See <i>Content Playing Order</i> below.
align12	Alignment of 12-bit binary pixel data. '1' aligned to LSB; '0' aligned to MSB.
audioswap	'1' for Little Endian audio samples
audiocompressed	1 compressed audio; 0 uncompressed audio
audiosampling	Audio sampling rate (e.g. 44100)
audiochannels	Number of audio channels
audiobits	Audio bits per sample (usually 16 or 24)
scramble	1 scrambling enabled; 0 scrambling disabled
colorspace	Video color space: RGB; YUV444; YUV422; YUV420
bitspercolor	Video color depth (bits per color)
timing.hactiv	Timing: horizontal active
timing.vactiv	Timing: vertical active
timing.htota	Timing: horizontal total
timing.vtotal	Timing: vertical total
timing.hstart	Timing: horizontal start
timing.vstart	Timing: vertical start
timing.hsync	Timing: horizontal sync width
timing.vsyn	Timing: vertical sync width
timing.frate	Timing: framerate in milliseconds
hdcp	HDCP version used (can be 1.4 2.3 or 'none')
loadingRGB	The R, G and B color components of uniform color pattern shown when content is being uploaded to the device before playback (e.g.0,0,0)

## Content Play Order

Play order is a sequence of steps. Steps are delimited with semicolons (;).

Each step has:

- Range (possibly numbered e.g. allm\_000.jpg, allm\_001.jpg, ...) of video frame(s)
- How many times the frame(s) are played
- Packet(s) (possibly numbered e.g. allm\_0.bin, allm\_1.bin, ...) indices to be sent during the video frame(s) transmission
- Color format
- Optional frame rate when VRR/Adaptive-Sync is enabled

## Format

Each scenario step is described in the form:

pV:R:E:FvXX;

## Parameters

Char	Description	Possible values	Examples
:	Required. Separator between general step parameters.	'.'	<i>See any below</i>
;	Required. Indication of step description end.	','	<i>See any below</i>
V	Required. Index (zero based) of video frame. Images are loaded from the <i>video</i> file path. Specifies a range of image(s). The order in which images are called in a <i>scenario</i> is optional. Specified parameters are applied to all frames in the step	'1' '0-59'	'1:60:16:256;' '0-59:60:16:256;'
R	Required. Repetitions of current step. E.g., stating '1' with 60 FPS frame rate means that current step will be played only for 1/60 of a second.	'30' '1'	'1:30:16:256;' '1:1:16:256;'
E	Optional. Metadata packet indices (zero based): A single packet or a comma separated list of packets. The index may be of the form 3l15 (lower case 'l'). At which vertical line do we want to put our packet in. 3l15 means insert packet 3 at line 15. Packets are loaded from the <i>packets</i> path.	'0' '4,1,29' <i>none</i> 3l15	'1:30:0:256;' '1:30:4,1,29:256;' '1:30::256;' 0:10000:3l15:256;
F	Required. Color Format and color depth. See Color Format below.	'256' '513'	'1:30:0:256;' '1:30:0:513;'
vXX	Optional. Control of frame rate when VRR/Adaptive-Sync is enabled. In order to enable VRR/Adaptive-Sync, the corresponding event must be included in this step. The parameter is always in format of 'vXX', where 'XX' states frame rate. The parameter is provided after color format value, separated with 'v'.	'v60' 'v30'	'1:30:0:256v60;' '1:30:0:256v30;'

## Color Format

Color format is a two-byte decimal value: The lower byte is the index to the color space and the higher byte the index to the color depth. See below.

Index	Color Depth (bits/color)	Color Space
0	6	RGB
1	8	YCbCr 4:4:4
2	10	YCbCr 4:2:2
3	12	YCbCr 4:2:0
4	16	-

The encoded parameter value is encoded as follows:

$$[Color\ Depth] \times 256 + [Color\ Space],$$

where *[Color Depth]* and *[Color Space]* are indices from the table above.

For example, parameter for YCbCr 4:4:4, 10 bits is  $(2 \times 256 + 1) = 513$ .

Pre-calculated values for available color formats are shown below:

	6 BPC	8 BPC	10 BPC	12 BPC	16 BPC
RGB	0	256	512	768	1024
YCbCr 4:4:4	N/A	257	513	769	1025
YCbCr 4:2:2	N/A	258	514	770	1026
YCbCr 4:2:0	N/A	259	515	771	1027

## Example

Please find below description of Playlist SDR-HDR-HLG – HDMI.

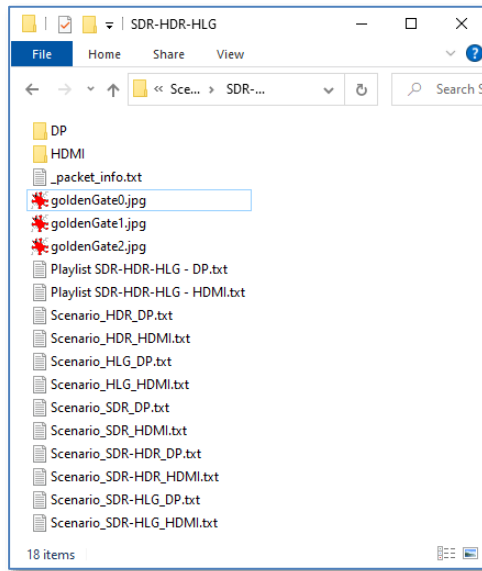

### Playlist file (Playlist SDR-HDR-HLG - HDMI.txt)

Playlist item and example content	Description
[Device]	Start of device section
serialnumber=*	Only one UCD device present.
connectortype=HDMI Out	HDMI output
[Scenario]	Start of Scenario 1
caption = SDR	Scenario title "SDR"
period = 10000	Duration 10 sec
path = Scenario_SDR_HDMI.txt	Scenario file: Scenario_SDR_HDMI.txt in current folder
[Scenario]	Start of Scenario 2
caption = HDR	Scenario title "HDR"
period = 10000	Duration 10 sec
path = Scenario_HDR_HDMI.txt	Scenario file: Scenario_HDR_HDMI.txt in current folder
[Scenario]	Start of Scenario 3
caption = HLG	Scenario title "HLG"
period = 10000	Duration 10 sec
path = Scenario_HLG_HDMI.txt	Scenario file: Scenario_HLG_HDMI.txt in current folder
[Scenario]	Start of Scenario 4
caption = SDR – HDR	Scenario title "SDR – HDR"
period = 10000	Duration 10 sec
path = Scenario_SDR-HDR_HDMI.txt	Scenario file: Scenario_SDR-HDR_HDMI.txt in current folder
[Scenario]	Start of Scenario 5
caption = SDR – HLG	Scenario title "SDR – HLG"
period = 10000	Duration 10 sec
path = Scenario_HDR_HDMI.txt	Scenario file: Scenario_SDR-HLG_HDMI.txt in current folder

## Scenario File (Scenario\_SDR-HDR-HDMI.txt)

Scenario item and example content	Description
video=goldenGate0.jpg	Video files in current folder, file name format goldenGate0.jpg (0...)
audio=<Audio not selected>	Audio not selected
packets=HDMI\Infoframes_0000.bin	Packet files in folder HDMI\, file name format Infoframes_0000.bin (0...)
porder=0:180:2:256;1:180:2,0:256;	180 frames of image index 0, Packet index 2, RGB 8 bpc 180 frames of image index 1, Packets index 2 and 0, RGB 8 bpc
align12=1	Pixel data is aligned to LSB
audioswap=0	-
audiocompressed=0	-
audiosampling=0	-
audiochannels=0	-
audiobits=0	-
scrambler=0	scrambling disabled
colospace=RGB444	Video color space: RGB 4:4:4
bitspercolor=8	Video color depth: 8 (bpc)
timing.hactive=1920	Timing: Horizontal active
timing.vactive=1080	Timing: Vertical active
timing.htotal=2200	Timing: Horizontal total
timing.vtotal=1125	Timing: Vertical total
timing.hstart=192	Timing: Horizontal start
timing.vstart=41	Timing: Vertical start
timing.hsync=44	Timing: Horizontal sync width
timing.vsync=5	Timing: Vertical sync width
timing.frate=60000	Timing: Frame rate 60 fps
hdcpc=none	HDCP not enabled
loadingRGB=52,127,150	Solid color pattern shown when content is being uploaded to the device before playback is R=52, G=127, B=150. (Sample:  )

## Sample Content in Playback Tab

UCD Console's Playback tab features a set of examples for the user to create custom test content. This content is stored by default in *C:\Program Files\Unigraf\Unigraf UCD Tools\data\playback\content*. It is advisable to create copy of the installed files and edit the copies.

**Note:** Playlists and Scenarios are interface technology dependent. The provided examples are different for HDMI and DisplayPort.

Provided examples for each interface are shown below:

### DP

The following playlists are available for DisplayPort interface.

Playlist Name	Description	Location
Basic Video & Audio Example	Example playlist for demonstrating the use of video and audio files.	<i>C:\Program Files\Unigraf\Unigraf UCD Tools\data\playback\content\Basic</i>
Frame Rate Example	Playlist for demonstrating use of multiple frame rates with FHD and UHD resolution.	<i>C:\Program Files\Unigraf\Unigraf UCD Tools\data\playback\content\VRR</i>
Audio-Video Latency	These scenarios can be used to estimate audio-video synchronization using external tools like Sync-One2 or similar.	<i>C:\Program Files\Unigraf\Unigraf UCD Tools\data\playback\content\AV Latency</i>
HDR & Metadata Example	Example playlist that demonstrates the use of video files and metadata packets in testing a DUT monitor	<i>C:\Program Files\Unigraf\Unigraf UCD Tools\data\playback\content\HDR Golden Gate</i>
Grayscale	The scenarios show smooth transition through shades of gray from black to white.	<i>C:\Program Files\Unigraf\Unigraf UCD Tools\data\playback\content\Grayscale</i>
HDR10+ SSTM Example	Playlist demonstrates using HDR10+ SSTM VSIF for Source-Side Tone Mapping.	<i>C:\Program Files\Unigraf\Unigraf UCD Tools\data\playback\content\SBTM-SSTM</i>
PSR1	A set of static images transmitted with matching Dolby Vision metadata.	<i>C:\Program Files\Unigraf\Unigraf UCD Tools\data\playback\content\Panel Replay</i>

## Playlist: Basic Video & Audio Example

The playlist sequences video files and audio according to the description below.

### Video

Frames used for Scenario 1 and Scenario 2 (Image1.jpg, Image 2.jpg)



Frame used for Scenario 3 and Scenario 4 (Philips.svg)

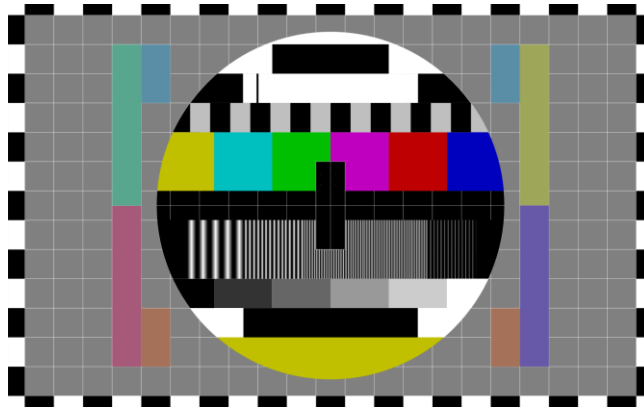

### Description of Scenarios

	Name	Duration	Repeated sequence
1	Flip-flop with LPCM Audio	60 s	CTA 1920x1080 60 Hz (VIC 16), RGB 8 BPC, 60 frames Image1.jpg, 60 frames Image2.jpg, Audio: Rhythm.wav
2	Flip-flop with AC3 Audio	60 s	CTA 1920x1080 60 Hz (VIC 16), RGB 8 BPC, 60 frames Image1.jpg, 60 frames Image2.jpg, Audio: 44100Hz_16bit_AC3_2channels_60sec_sine.iec61937.bin
3	Flip-flop Silent	60 s	CTA 1920x1080 60 Hz (VIC 16), RGB 8 BPC, 60 frames Image1.jpg, 60 frames Image2.jpg, No Audio.
4	Philips 1920x1080p + 1kHz	60 s	CTA 1920x1080 60 Hz (VIC 16), RGB 8 BPC, 60 Frames Philips.svg, Audio: 1 kHz sine wave (1kHz.wav)
5	Philips 3840x2160p + 1kHz	60 s	CTA 3840 x 2160 @ 60Hz (VIC 97), RGB 8 BPC, 60 Frames Philips.svg, Audio: 1 kHz sine wave (1kHz.wav)

## Playlist: Audio-Video Latency

---

**Note:** To measure video latency, ULT-01 test tool is needed.

---

### Description of Scenarios

These scenarios can be used to estimate audio-video synchronization using external tools like Sync-One2 or similar. Video latency measuring requires the Unigraf ULT-01 tool.

The pattern with a white patch is shown for 15 frames, and then the black screen is shown for 45 frames. The audio beep is transmitted during the first frame of a white patch pattern.

	Name	Duration	Repeated sequence
1	vic16	60 s	CTA 1920×1080 60 Hz (VIC 16), RGB 8 BPC, 15 frames frame1.vpattern, 45 frame0.vpattern, Audio: beep.wav
2	vic97	60 s	CTA 3840×2160 60 Hz (VIC 97), RGB 8 BPC, 45 frames frame1.vpattern, 15 frame0.vpattern, Audio: beep.wav

### Video

Frames used for the scenario (frame1.vpattern frame0.vpattern)

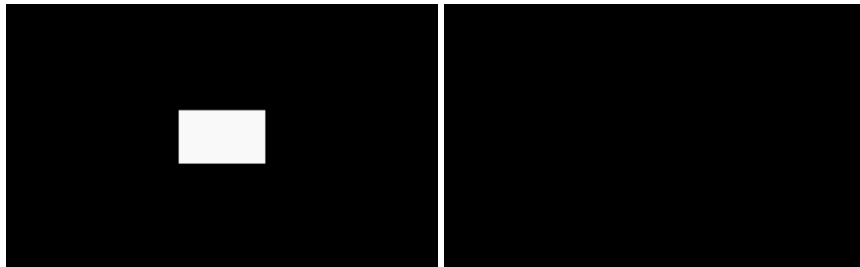

## Playlist: HDR & Metadata Example

Example demonstrates the use of metadata packets.

### Video:

The Scenarios use four versions of the same image: GoldenGate0.jpg, GoldenGate1.jpg, GoldenGate2.jpg and GoldenGate3.jpg.

All four images use the same dynamic range in pixel data but contain a text label indicating pixel dynamic range applied in the metadata. If DUT behaves correctly, applying different metadata changes the appearance of the image on DUT screen.



### Scenarios for HDMI Output

Video mode in all steps: CTA 1920×1080 60 Hz (VIC 16), RGB 8 BPC, No audio.

Name	Duration	Repeated sequence
SDR	10 sec	180 frames GoldenGate0.jpg, Packet: Infoframes_0002;
HDR	10 sec	180 frames GoldenGate1.jpg, Packets: Infoframes_0002, Infoframes_0000
HLG	10 sec	180 frames GoldenGate2.jpg, Packets: Infoframes_0001, Infoframes_0002
HDR10+	10 sec	180 frames GoldenGate3.jpg, Packets: Infoframes_0002, Infoframes_0003, Infoframes_0000
SDR – HDR	10 sec	180 frames GoldenGate0.jpg, Packets: Infoframes_0002; 180 frames GoldenGate1.jpg, Packets: Infoframes_0002, Infoframes_0000
SDR – HLG	10 sec	180 frames GoldenGate0.jpg, Packet: – ; 180 frames GoldenGate2.jpg, Packets: Packets: Infoframes_0001, Infoframes_0002
SDR – HDR10+	10 sec	180 frames GoldenGate0.jpg, Packet: Infoframes_0002; 180 frames GoldenGate3.jpg, Packets: Infoframes_0002, Infoframes_0003, Infoframes_0000

## Playlist: Grayscale

### Description of Scenarios

The scenarios show smooth transition though shades of gray from black to white.

	Name	Duration	Repeated sequence
1	GrayFHD_60	60 s	CTA 1920×1080 60 Hz (VIC 16), RGB 12 BPC, 120 frames: gray0.vpattern - gray119.vpattern, Audio: No audio
2	GrayUHD_119	60 s	CTA 3840×2160 119,88 Hz, RGB 12 BPC, 120 frames: gray0.vpattern - gray119.vpattern, Audio: No audio

### Video

Below you can see three example frames from the video.

Gray0.vpattern

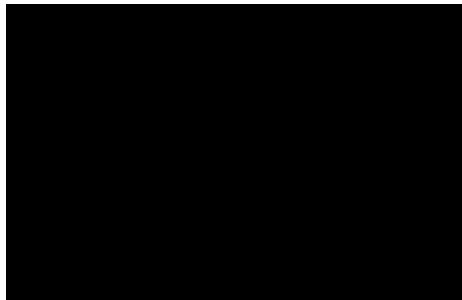

Gray60.vpattern



Gray119.vpattern

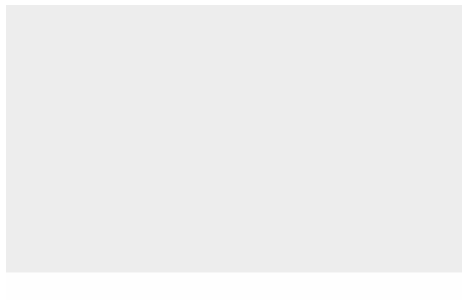

## Playlist: HDR10+ SSTM Example

Playlist demonstrates using HDR10+ SSTM VSIF for Source-Side Tone Mapping.

	Name	Duration	Repeated sequence
1	HDR10+ SSTM	10 s	3840x2160 30 Hz, RGB 10 BPC, Video: Channel0.jpg, repeated 180 times Packets: Infoframes_0000.bin, _0003.bin Audio: No audio
2	SDR – HDR10+ SSTM	10 s	3840x2160 30 Hz, RGB 10 BPC, Video: Step1: Channel0.jpg, repeated 150 times Packets: Infoframes_0000.bin, _0003.bin Step2: Channel1.jpg, repeated 150 times Packets: None  Audio: No audio

### Video

Channel0.jpg



Channel1.jpg

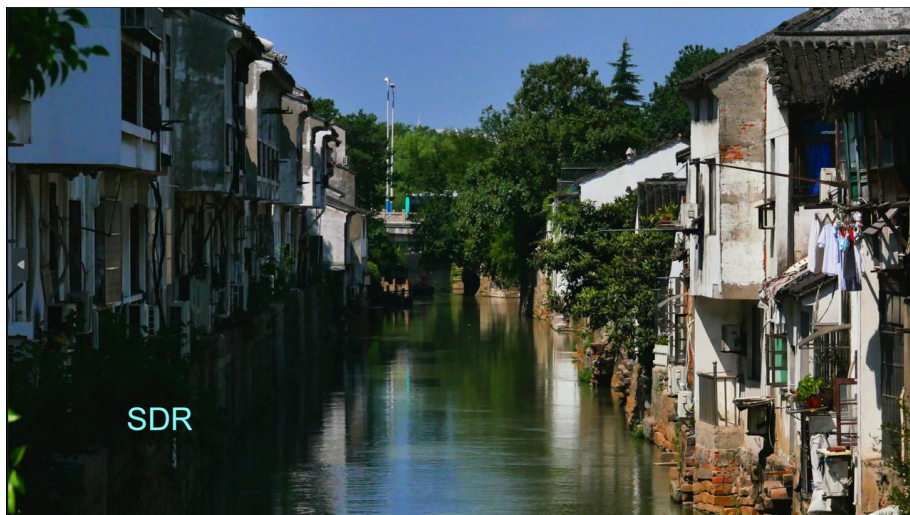

## Playlist: Frame Rate Example

Playlist for demonstrating use of multiple frame rates with FHD and UHD resolution when using DisplayPort output.

### Video

The image used for the test contains a combination of color bars, gray scales, and rotating items. The test uses a sequence of images creating a full rotation in 60 frames



### Executed Scenarios

The test is using four scenarios (RGB 8 BPC, No audio)

	Name	Duration	Repeated sequence
1	Spinners FHD 59fps	60 s	1920×1080 59.94/60 Hz video timing (VIC 16), 60 frames 'colorBarsSpinning-X.svg' X= 0 to 59
2	Spinners FHD 119fps	60 s	1920×1080 119.88/120 Hz video timing (VIC 63), 60 frames 'colorBarsSpinning-X.svg' X= 0 to 59
3	Spinners UHD 59fps	60 s	3840×2160 59.94/60 Hz video timing (VIC 97) 60 frames 'colorBarsSpinning-X.svg' X= 0 to 59
4	Spinners UHD 119fps	60 s	3840×2160 119.88/120 Hz video timing (VIC 120) 60 frames 'colorBarsSpinning-X.svg' X= 0 to 59

## Playlist: PSR1

Playlist for demonstrating Panel Replay functionality.

### Video:

The Scenarios use color\_bars\_0.jpg image.

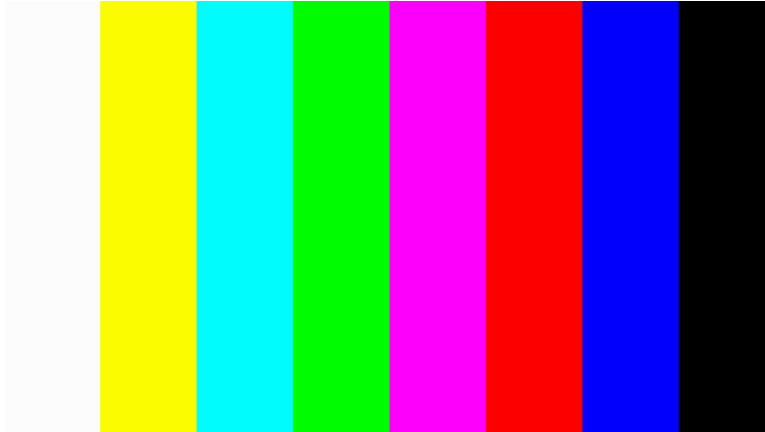

### Scenarios

Video mode in all steps: CTA 1920×1080 60 Hz (VIC 16), RGB 8 bpc, No audio.

Name	Duration	Repeated sequence
PSR1 Entry N	10 sec	color_bars_0.jpg.jpg, Packets: DP/vscpacket_0000.bin on line 0; color_bars_0.jpg.jpg, Packets: DP/vscpacket_0001.bin on line 1; color_bars_0.jpg.jpg, Packets: DP/vscpacket_0003.bin on line 15;
PSR1 Entry N p 1	10 sec	color_bars_0.jpg.jpg, Packets: DP/vscpacket_0000.bin
PSR1 Abort N p 1	10 sec	color_bars_0.jpg.jpg, Packets: DP/vscpacket_0000.bin
PSR1 Abort N p 2	10 sec	color_bars_0.jpg.jpg, Packets: DP/vscpacket_0000.bin